

# Roller Bearing

# 45kg

## SLIDING DOOR SYSTEM

PER DOOR

### DOUBLE TRACK FOR 6MM FLOAT & 6.38MM LAMINATE GLASS PANELS

DESIGNED FOR INTERNAL USE ONLY

Stock finishes: Mill and clear anodised

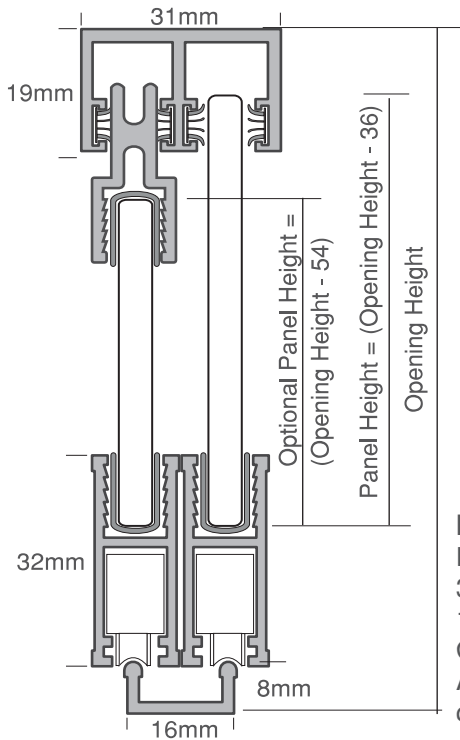

TT24 (Optional)

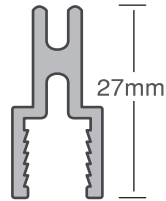

#### RECOMMENDED

Maximum sizes:  
3.78 Sq mt each panel  
1800mm high  
Overlap: As desired  
All edges to be polished and all corners to be rounded or tipped

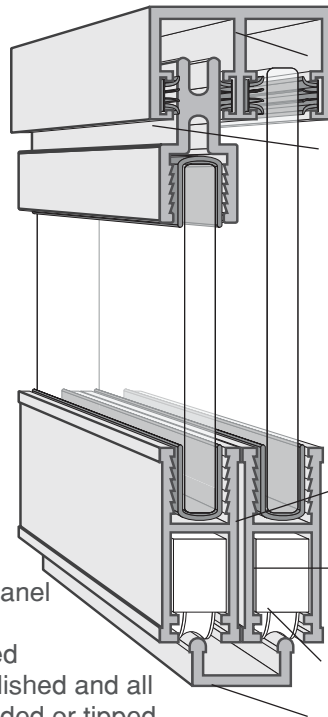

TT21 Aluminium double headguide with pile inserts - 4500mm length

TT24 Aluminium head race (Optional) 4500mm Length

TT87 Glazing rubber  
TT89 Glazing wedge

TT48 Aluminium race section  
With pile insert  
-4500mm length

TT500A & TT500B Adjustable sheave

TT47 Aluminium double track - 4500mm length

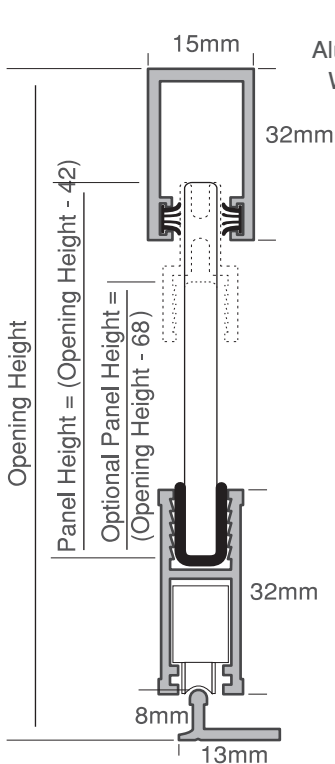

TT23 Aluminium single headguide  
With pile inserts - 4500mm Length

TT87 Glazing rubber  
TT89 Glazing wedge

TT48 Aluminium race section  
4500mm Length

TT500A or TT500B Adjustable sheave

TT416 Aluminium single track  
5000mm length

#### NOT RECOMMENDED FOR EXTERNAL USE IN EXPOSED CONDITIONS

APPLICABLE TO BOTH SYSTEMS

TT46 Nylon end plate fits into TT48 race Available in white, black, & silver

TT48

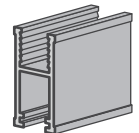

TT46

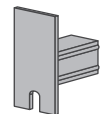

Adjustable Sheave -  
TT500A Stainless steel wheel (45kg per pair)  
TT500B nylon wheel (30kg per pair)

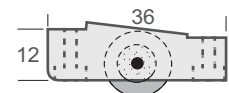

TT87 Glazing rubber 20 or 30m roll or per M  
TT89 Glazing wedge 40m roll or per M used to secure glass into TT48 and TT24

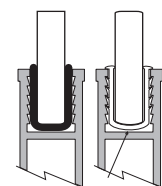

TT87 TT89