

Master Universal

SISTEMA SCORREVOLE ANTE SOVRAPPOSTE

- sistema di scorrimento tradizionale per armadi con ante non complanari;
- la modularità di sistema differenziata da maggiore a minore portata, consente numerose versioni e possibilità di utilizzo;
- binari realizzati in alluminio anodizzato;
- il peso delle ante viene scaricato sul binario superiore;
- inserimento automatico a scatto della base dell'anta;
- facilità di regolazione di altezza e verticalità delle ante;
- carrello scorrevole dotato di antiscarrucolamento;
- DOTATO DI UN INNOVATIVO SISTEMA AMMORTIZZATO IN GRADO DI RALLENTARE E BLOCCARE L'ANTA.

SYSTEME COULISSANT

- système de coulissement traditionnel pour armoires avec portes non complanaires;
- système par éléments, à la modularité différente selon le débit, plus haut ou plus bas, qui met à disposition un grand nombre de modèles et un grand éventail d'opportunités d'emploi;
- rails en aluminium anodisé;
- le poids de la porte est déchargé sur le rail supérieur;
- mise en place automatique à déclat de la base de la porte;
- réglage de la hauteur et de la verticalité de la porte plus facile;
- chariot équipé d'un dispositif contre le déraillement;
- DOTÉ D'UN DISPOSITIF D'AMORTISSEMENT INNOVANT CAPABLE DE RALENTIR ET DE BLOQUER LE VANTAIL.

SLIDING SYSTEM

- traditional sliding system for wardrobes with non-aligned doors;
- being modular, the system, which varies according to the load it can carry, lends itself to creating numerous versions with many different uses;
- rails made of anodised aluminium;
- the weight of the doors is leaned to the upper rail;
- automatic insertion with deadlatch of the base of the doors;
- great easy in the adjustment of the height and the door's verticality;
- sliding truck equipped with antifeeting device;
- FITTED WITH NEW SHOCK-ABSORBERS TO SLOW DOWN AND STOP THE DOOR.

GLEITSYSTEM

- Traditionelles Gleitsystem für Schränke mit Türen nicht komplanarchhieden;
- Die Modularität des Systems, unterschiedlich durch höhere und niedrigere Tragfähigkeit, ermöglicht zahlreiche Versionen und Verwendungsmöglichkeiten;
- Schienen aus eloxiertem Aluminium;
- das Gewicht der Türen wird von den oberen Schienen getragen;
- ein Schnappsystem ermöglicht den automatischen Einsatz der Türbasis;
- einfachere Regulierung der Höhe und der vertikalen Lage der Tür;
- Gleitschlitten mit abfallsicherem System ausgestattet;
- AUSGESTATTET MIT EINEM NEUEN PUFFERSYSTEM, WELCHES DIE TÜR ABBREMST UND BLOCKIERT.

SISTEMA DE DESLIZAMIENTO

- sistema de deslizamiento tradicional para armarios con puertas no complanares;
- la modularidad del sistema, que se diferencia por su mayor y menor capacidad, permite crear varias soluciones y ofrece muchas posibilidades de empleo;
- carriles de aluminio anodizado;
- el carril superior debe sostener el peso de las puertas;
- introducción automática con resarte de la base de la puerta;
- con este sistema es más fácil ajustar la altura y la verticalidad de la puerta;
- sistema que impide que el carro de deslizamiento se salga del carril;
- DOTADO DE UN NOVEDOSO SISTEMA AMORTIGUADO CAPAZ DE RALENTIZAR Y BLOQUEAR LA HOJA.

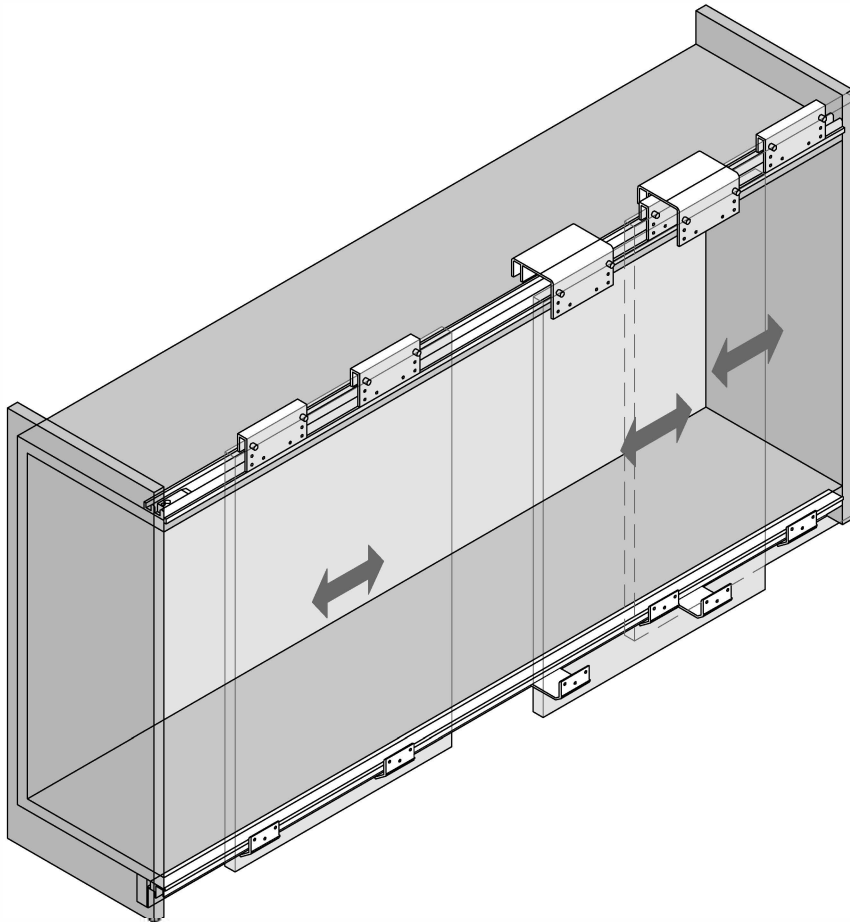

Master Universal

peso anta - door weight **70 kg**

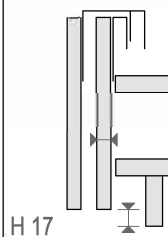
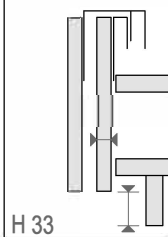
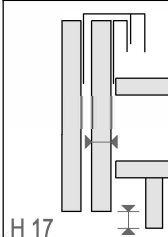
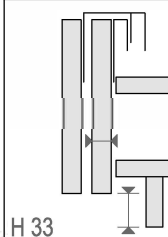
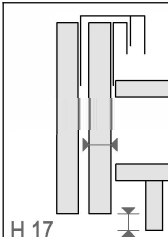
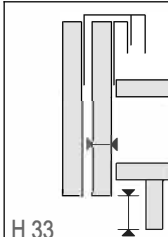
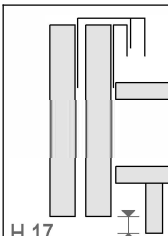
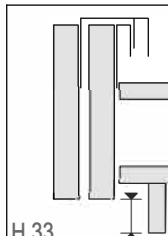
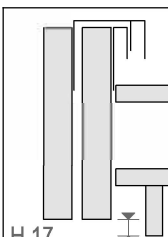
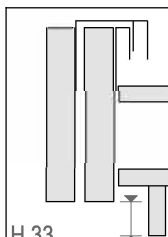
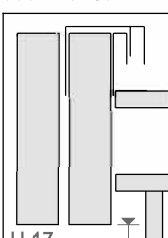
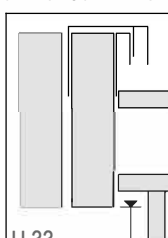
spessore anta - door thickness	H17	H33
<p>EXTRA MINI spessore anta fino a 18 mm door thickness to 18 mm</p>	<p>int. door MU 141 - MU 60 ext. door MU 30 - MU 48</p>  <p>H 17</p>	<p>int. door MU 141 - MU 61 ext. door MU 30 - MU 49</p>  <p>H 33</p>
<p>MINI spessore anta fino a 23 mm door thickness to 23 mm</p>	<p>int. door MU 141 - MU 60 ext. door MU 31 - MU 50</p>  <p>H 17</p>	<p>int. door MU 141 - MU 61 ext. door MU 31 - MU 51</p>  <p>H 33</p>
<p>EXTRA MIDI spessore anta fino a 26 mm door thickness to 26 mm</p>	<p>int. door MU 141 - MU 60 ext. door MU - MU</p>  <p>H 17</p>	<p>int. door MU 141 - MU 61 ext. door MU - MU</p>  <p>H 33</p>
<p>MIDI spessore anta fino a 30 mm door thickness to 30 mm</p>	<p>int. door MU 141 - MU 60 ext. door MU 34 - MU 53</p>  <p>H 17</p>	<p>int. door MU 141 - MU 61 ext. door MU 34 - MU 54</p>  <p>H 33</p>
<p>MAXI spessore anta fino a 35 mm door thickness to 35 mm</p>	<p>int. door MU 141 - MU 60 ext. door MU 37 - MU 56</p>  <p>H 17</p>	<p>int. door MU 141 - MU 61 ext. door MU 37 - MU 57</p>  <p>H 33</p>
<p>EXTRA spessore anta fino a 50 mm door thickness to 50 mm</p>	<p>int. door MU 141 - MU 60 ext. door MU 39 - MU 58</p>  <p>H 17</p>	<p>int. door MU 141 - MU 61 ext. door MU 39 - MU 59</p>  <p>H 33</p>

Master Universal

peso anta - door weight **100 kg**

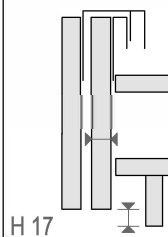
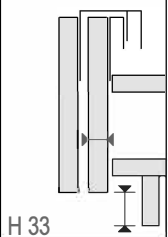
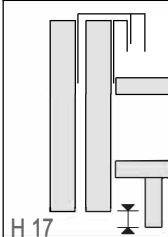
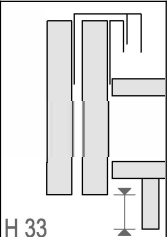
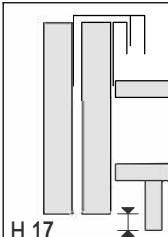
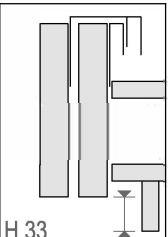
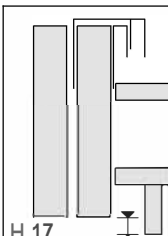
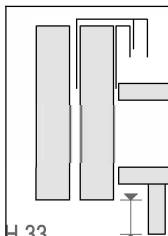
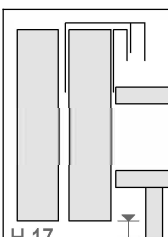
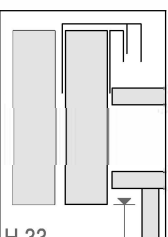
spessore anta - door thickness	H17	H33
<p>MINI STRONG spessore anta fino a 23 mm door thickness till 23 mm</p>	<p>int. door MU 141 - MU 60 ext. door MU 131 - MU 50</p> 	<p>int. door MU 141 - MU 61 ext. door MU 131 - MU 51</p> 
<p>MIDI STRONG spessore anta fino a 30 mm door thickness till 30 mm</p>	<p>int. door MU 141 - MU 60 ext. door MU 134 - MU 53</p> 	<p>int. door MU 141 - MU 61 ext. door MU 134 - MU 54</p> 
<p>MAXI STRONG spessore anta fino a 35 mm door thickness till 35 mm</p>	<p>int. door MU 141 - MU 60 ext. door MU 137 - MU 56</p> 	<p>int. door MU 141 - MU 61 ext. door MU 137 - MU 57</p> 
<p>SUPER MAXI STRONG spessore anta fino a 40 mm door thickness till 40 mm</p>	<p>int. door MU 141 - MU 60 ext. door MU 138 - MU 52</p> 	<p>int. door MU 141 - MU 61 ext. door MU 138 - MU 55</p> 
<p>EXTRA STRONG spessore anta fino a 50 mm door thickness till 50 mm</p>	<p>int. door MU 141 - MU 60 ext. door MU 139 - MU 58</p> 	<p>int. door MU 141 - MU 61 ext. door MU 139 - MU 59</p> 

Master Universal

peso anta - door weight max 70 kg

EXTRA MINI

spessore anta - door thickness max 18 mm

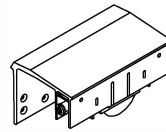
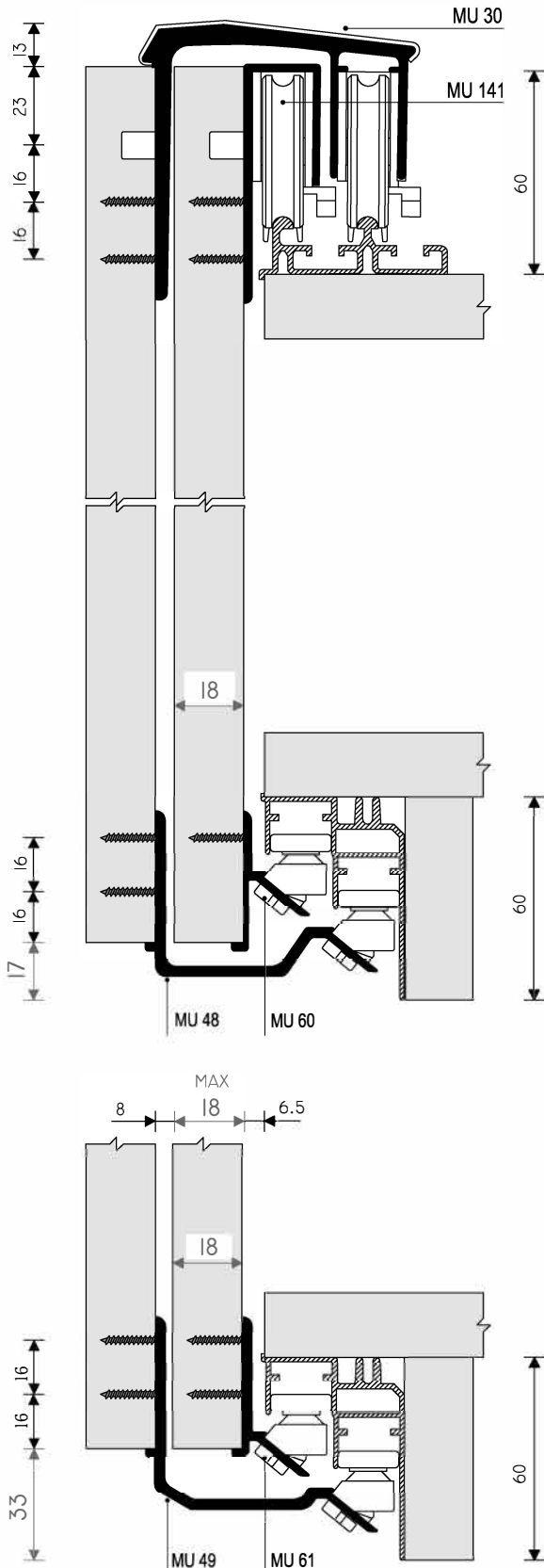

- Carrello superiore anta esterna
- Chariot supérieur porte extérieure
- Upper truck of external door
- Obere Schlitten Außentür
- Carro superior puerta externa

MU 30

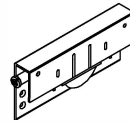

- Carrello superiore anta interna
- Chariot supérieur porte intérieure
- Upper truck of internal door
- Obere Schlitten Innentür
- Carro superior puerta interna

MU 141



- Attivatore con vite
- Actvator avec vis
- Activator with screw
- Activator mit Schraube
- Activador con tornillo

MUT 92

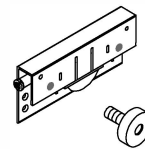

- Carrello speciale superiore anta interna con salvamaniglia
- Chariot special supérieur porte intérieure avec petit bouchon en caoutchouc d'arrêt
- Upper special truck of internal door with rubber stop
- Obere Special Schlitten Innentür mit Stopper aus Gummi zwischen den Türen
- Carro special superior puerta interna con gomita de tope

MU 145

MM 95

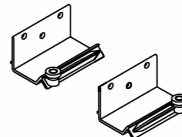

- Pattini inferiori anta esterna
- Câles inférieurs porte extérieure
- Lower sliders of external door
- Untere Laufwerk Außentür
- Patínos inferior puerta externa

MU 48 R
MU 48 L

H 17

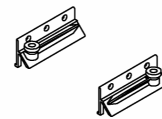

- Pattini inferiori anta interna
- Câles inférieurs porte intérieure
- Lower sliders of internal door
- Untere Laufwerk Innentür
- Patínos inferior puerta interna

MU 60 R
MU 60 L

H 17

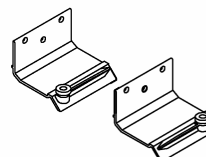

- Pattini inferiori anta esterna
- Câles inférieurs porte extérieure
- Lower sliders of external door
- Untere Laufwerk Außentür
- Patínos inferior puerta externa

MU 49 R
MU 49 L

H 33

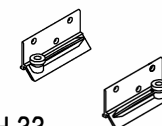

- Pattini inferiori anta interna
- Câles inférieurs porte intérieure
- Lower sliders of internal door
- Untere Laufwerk Innentür
- Patínos inferior puerta interna

MU 61 R
MU 61 L

H 33

Master Universal

peso anta - door weight max 70 kg

BINARI - RAILS

ACCESSORI - ACCESSORIES



- Binario superiore
- Rail supérieur
- Upper rail
- Obere Schiene
- Carril superior

ML10

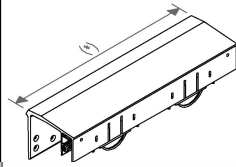

- Carrello superiore anta esterna
- Chariot supérieur porte extérieure
- Upper truck of external door
- Obere Schlitten Außentür
- Carro superior puerta externa

MU30

*misura cliente, sur mesure, made-to-measure, Maßgerecht, a medida

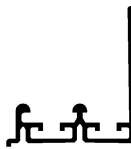

- Binario superiore
- Rail supérieur
- Upper rail
- Obere Schiene
- Carril superior

ML13

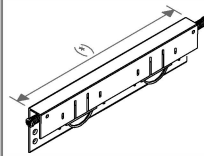

- Carrello superiore anta interna
- Chariot supérieur porte intérieure
- Upper truck of internal door
- Obere Schlitten Innentür
- Carro superior puerta interna

MU141

*misura cliente, sur mesure, made-to-measure, Maßgerecht, a medida

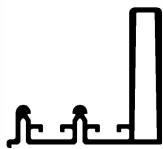

- Binario superiore
- Rail supérieur
- Upper rail
- Obere Schiene
- Carril superior

ML16

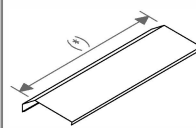

- Parapolvere superiore anta esterna
- Garde-poussière supérieur porte extérieure
- Upper dust cover of external door
- Obere Staubprofil Außentür
- Guardapolvo superior puerta externa

ML71

*misura cliente, sur mesure, made-to-measure, Maßgerecht, a medida



- Binario inferiore
- Rail inférieur
- Lower rail
- Untere Schiene
- Carril inferior

ML20



- Fermo superiore ammortizzato
- Arrêt supérieur amortis
- Upper amortized stopper
- Obere Stopper amortisiert
- Tope superior amortizado

MUC92SK LUXE



- Binario superiore
- Rail supérieur
- Upper rail
- Obere Schiene
- Carril superior

MQ10

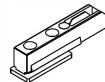

- Fermo superiore
- Arrêt supérieur
- Upper stopper
- Obere Stopper
- Tope superior

MU92

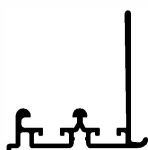

- Binario superiore
- Rail supérieur
- Upper rail
- Obere Schiene
- Carril superior

MQ13



- Fermo inferiore
- Arrêt inférieur
- Lower stopper
- Unterer Stopper
- Tope inferior

ML93

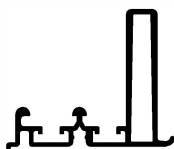

- Binario superiore
- Rail supérieur
- Upper rail
- Obere Schiene
- Carril superior

MQ16



- Clip blocco binario superiore
- Clip bloquant rail supérieur
- Upper rail hook clip
- Clip sperren Sie die obere Schiene
- Clip bloquean el carril superior

MQ910

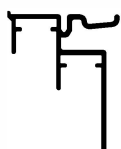

- Binario inferiore
- Rail inférieur
- Lower rail
- Untere Schiene
- Carril inferior

MQ20

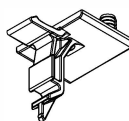

- Clip aggancio binario superiore
- Clip rail supérieur
- Upper rail clip
- Clip obere Schiene
- Clip de superior del carril

MQ911

- Clip binario inferiore
- Clip rail inférieur
- Lower rail clip
- Clip untere Schiene
- Clip de inferior del carril

MQ920

Master Universal

peso anta - door weight max 70 kg

MINI

spessore anta - door thickness max 23 mm

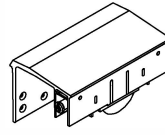
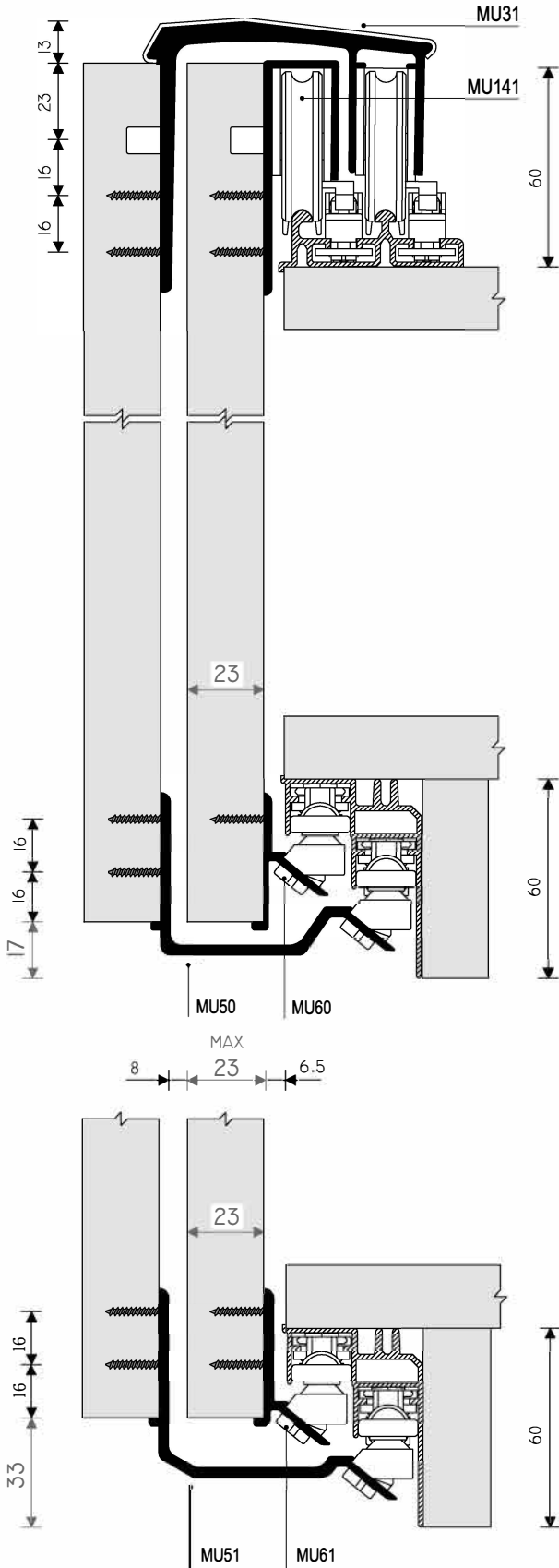

- Carrello superiore anta esterna
- Chariot supérieur porte extérieure
- Upper truck of external door
- Obere Schlitten Außentür
- Carro superior puerta externa

MU 31

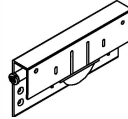

- Carrello superiore anta interna
- Chariot supérieur porte intérieure
- Upper truck of internal door
- Obere Schlitten Innentür
- Carro superior puerta interna

MU 141



- Attivatore con vite
- Activator avec vis
- Activator with screw
- Activator mit Schraube
- Activador con tornillo

MUT 92

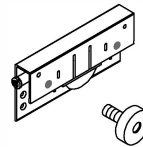

- Carrello speciale superiore anta interna con salvamaniglia
- Chariot special supérieur porte intérieure avec petit bouchon en caoutchouc d'arrêt
- Upper special truck of internal door with rubber stop
- Obere Special Schlitten Innentür mit Stopper aus Gummi zwischen den Türen
- Carro special superior puerta interna con gomita de tope

MU 145

MM 95

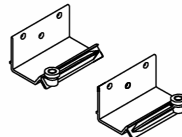

- Pattini inferiori anta esterna
- Câles inférieurs porte extérieure
- Lower sliders of external door
- Untere Laufwerk Außentür
- Patinos inferior puerta externa

MU 50 R
MU 50 L

H 17

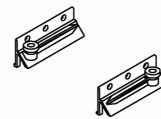

- Pattini inferiori anta interna
- Câles inférieurs porte intérieure
- Lower sliders of internal door
- Untere Laufwerk Innentür
- Patinos inferior puerta interna

MU 60 R
MU 60 L

H 17

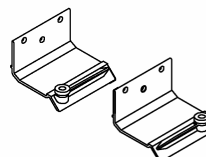

- Pattini inferiori anta esterna
- Câles inférieurs porte extérieure
- Lower sliders of external door
- Untere Laufwerk Außentür
- Patinos inferior puerta externa

MU 51 R
MU 51 L

H 33

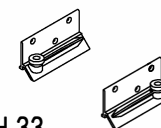

- Pattini inferiori anta interna
- Câles inférieurs porte intérieure
- Lower sliders of internal door
- Untere Laufwerk Innentür
- Patinos inferior puerta interna

MU 61 R
MU 61 L

H 33

Master Universal

peso anta - door weight max 70 kg

BINARI - RAILS

ACCESSORI - ACCESSORIES



- Binario superiore
- Rail supérieur
- Upper rail
- Obere Schiene
- Carril superior

ML10

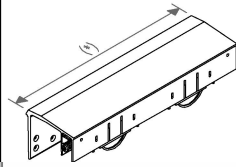

- Carrello superiore anta esterna
- Chariot supérieur porte extérieure
- Upper truck of external door
- Obere Schlitten Außentür
- Carro superior puerta externa

MU31

*misura cliente, sur mesure, made-to-measure, Maßgerecht, a medida

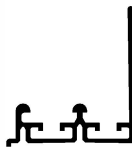

- Binario superiore
- Rail supérieur
- Upper rail
- Obere Schiene
- Carril superior

ML13

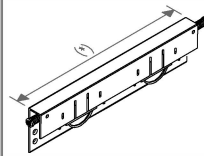

- Carrello superiore anta interna
- Chariot supérieur porte intérieure
- Upper truck of internal door
- Obere Schlitten Innentür
- Carro superior puerta interna

MU141

*misura cliente, sur mesure, made-to-measure, Maßgerecht, a medida

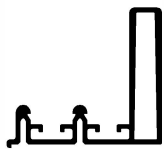

- Binario superiore
- Rail supérieur
- Upper rail
- Obere Schiene
- Carril superior

ML16

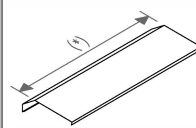

- Parapolvere superiore anta esterna
- Garde-poussière supérieur porte extérieure
- Upper dust cover of external door
- Obere Staubprofil Außentür
- Guardapolvo superior puerta externa

ML70

*misura cliente, sur mesure, made-to-measure, Maßgerecht, a medida

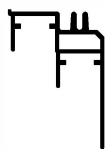

- Binario inferiore
- Rail inférieur
- Lower rail
- Untere Schiene
- Carril inferior

ML20



- Fermo superiore ammortizzato
- Arrêt supérieur amortis
- Upper amortized stopper
- Obere Stopper amortisiert
- Tope superior amortizado

MUC92SK LUXE



- Binario superiore
- Rail supérieur
- Upper rail
- Obere Schiene
- Carril superior

MQ10

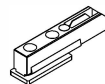

- Fermo superiore
- Arrêt supérieur
- Upper stopper
- Obere Stopper
- Tope superior

MU92

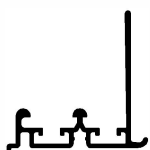

- Binario superiore
- Rail supérieur
- Upper rail
- Obere Schiene
- Carril superior

MQ13



- Fermo inferiore
- Arrêt inférieur
- Lower stopper
- Unterer Stopper
- Tope inferior

ML93

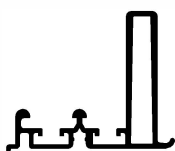

- Binario superiore
- Rail supérieur
- Upper rail
- Obere Schiene
- Carril superior

MQ16



- Clip blocco binario superiore
- Clip bloquant rail supérieur
- Upper rail hook clip
- Clip sperren Sie die obere Schiene
- Clip bloquean el carril superior

MQ910

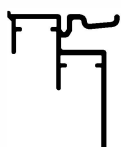

- Binario inferiore
- Rail inférieur
- Lower rail
- Untere Schiene
- Carril inferior

MQ20

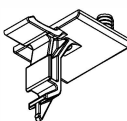

- Clip aggancio binario superiore
- Clip rail supérieur
- Upper rail clip
- Clip obere Schiene
- Clip de superior del carril

MQ911

- Clip binario inferiore
- Clip rail inférieur
- Lower rail clip
- Clip untere Schiene
- Clip de inferior del carril

MQ920

Master Universal

peso anta - door weight **70 kg**

EXTRA MIDI

spessore anta - door thickness **26 mm**

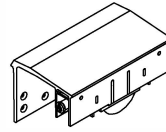
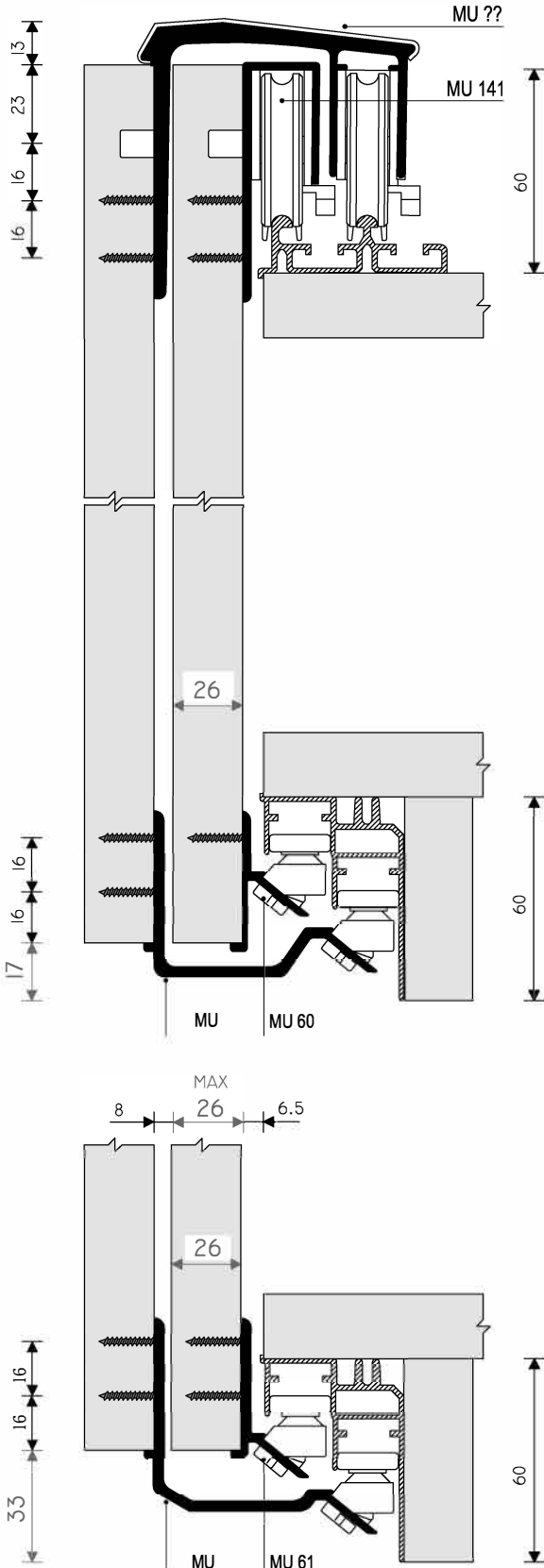

- Carrello superiore anta esterna
- Chariot supérieur porte extérieure
- Upper truck of external door
- Obere Schlitten Außentür
- Carro superior puerta externa

MU

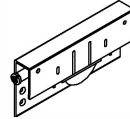

- Carrello superiore anta interna
- Chariot supérieur porte intérieure
- Upper truck of internal door
- Obere Schlitten Innentür
- Carro superior puerta interna

MU 141



- Attivatore con vite
- Activator avec vis
- Activator with screw
- Activator mit Schraube
- Activador con tornillo

MUT 92

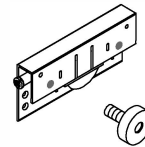

- Carrello speciale superiore anta interna con salvamaniglia
- Chariot special supérieur porte intérieure avec petit bouchon en caoutchouc d'arrêt
- Upper special truck of internal door with rubber stop
- Obere Special Schlitten Innentür mit Stopper aus Gummi zwischen den Türen
- Carro special superior puerta interna con gomita de tope

MU 145

MM 95

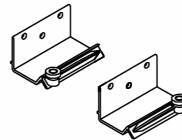

- Pattini inferiori anta esterna
- Câles inférieurs porte extérieure
- Lower sliders of external door
- Untere Laufwerk Außentür
- Patinos inferior puerta externa

MU R
MU L

H 17

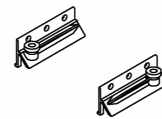

- Pattini inferiori anta interna
- Câles inférieurs porte intérieure
- Lower sliders of internal door
- Untere Laufwerk Innentür
- Patinos inferior puerta interna

MU 60 R
MU 60 L

H 17

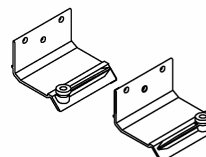

- Pattini inferiori anta esterna
- Câles inférieurs porte extérieure
- Lower sliders of external door
- Untere Laufwerk Außentür
- Patinos inferior puerta externa

MU R
MU L

H 33

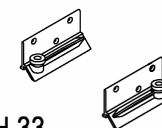

- Pattini inferiori anta interna
- Câles inférieurs porte intérieure
- Lower sliders of internal door
- Untere Laufwerk Innentür
- Patinos inferior puerta interna

MU 61 R
MU 61 L

H 33

Master Universal

peso anta - door weight **70 kg**

BINARI - RAILS

ACCESSORI - ACCESSORIES



- Binario superiore
- Rail supérieur
- Upper rail
- Obere Schiene
- Carril superior

ML10

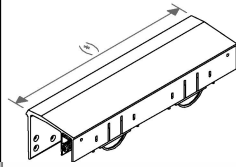

- Carrello superiore anta esterna
- Chariot supérieur porte extérieure
- Upper truck of external door
- Obere Schlitten Außentür
- Carro superior puerta externa

MU

*misura cliente, sur mesure, made-to-measure, Maßgerecht, a medida

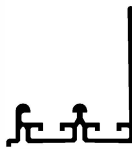

- Binario superiore
- Rail supérieur
- Upper rail
- Obere Schiene
- Carril superior

ML13

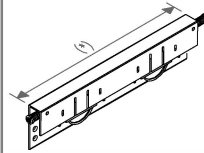

- Carrello superiore anta interna
- Chariot supérieur porte intérieure
- Upper truck of internal door
- Obere Schlitten Innentür
- Carro superior puerta interna

MU141

*misura cliente, sur mesure, made-to-measure, Maßgerecht, a medida

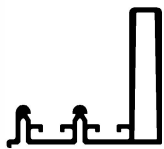

- Binario superiore
- Rail supérieur
- Upper rail
- Obere Schiene
- Carril superior

ML16

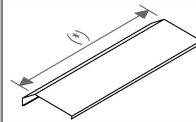

- Parapolvere superiore anta esterna
- Garde-poussière supérieur porte extérieure
- Upper dust cover of external door
- Obere Staubprofil Außentür
- Guardapolvo superior puerta externa

ML



- Binario inferiore
- Rail inférieur
- Lower rail
- Untere Schiene
- Carril inferior

ML20



- Fermo superiore ammortizzato
- Arrêt supérieur amortis
- Upper amortized stopper
- Obere Stopper amortisiert
- Tope superior amortizado

MUC92SK LUXE



- Binario superiore
- Rail supérieur
- Upper rail
- Obere Schiene
- Carril superior

MQ10

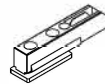

- Fermo superiore
- Arrêt supérieur
- Upper stopper
- Obere Stopper
- Tope superior

MU92

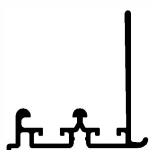

- Binario superiore
- Rail supérieur
- Upper rail
- Obere Schiene
- Carril superior

MQ13



- Clip blocco binario superiore
- Clip bloquant rail supérieur
- Upper rail hook clip
- Clip sperren Sie die obere Schiene
- Clip bloquean el carril superior

MQ910

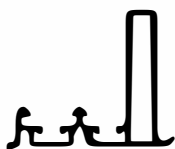

- Binario superiore
- Rail supérieur
- Upper rail
- Obere Schiene
- Carril superior

MQ16



- Clip aggancio binario superiore
- Clip rail supérieur
- Upper rail clip
- Clip obere Schiene
- Clip de superior del carril

MQ911

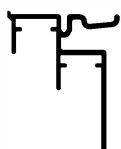

- Binario inferiore
- Rail inférieur
- Lower rail
- Untere Schiene
- Carril inferior

MQ20

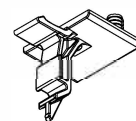

- Clip binario inferiore
- Clip rail inférieur
- Lower rail clip
- Clip untere Schiene
- Clip de inferior del carril

MQ920

Master Universal

peso anta - door weight **70 kg**

MIDI

spessore anta - door thickness **30 mm**

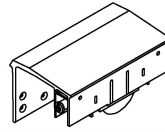
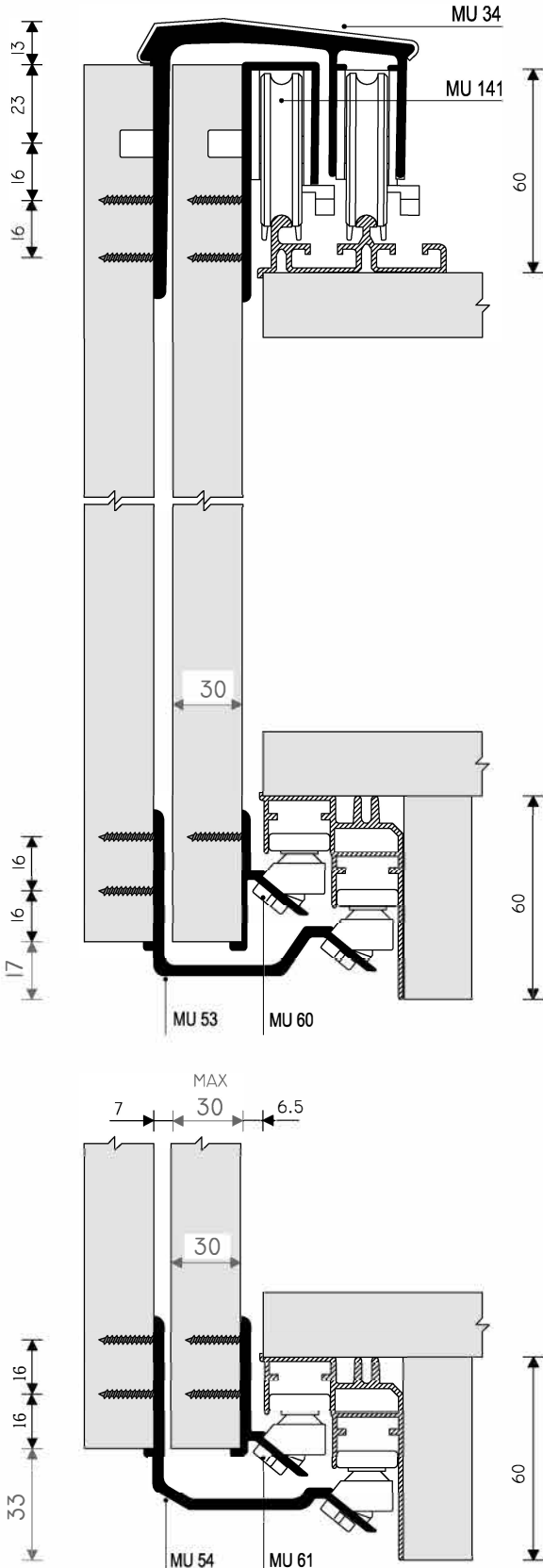

- Carrello superiore anta esterna
- Chariot supérieur porte extérieure
- Upper truck of external door
- Obere Schlitten Außentür
- Carro superior puerta externa

MU 34

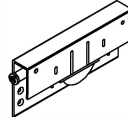

- Carrello superiore anta interna
- Chariot supérieur porte intérieure
- Upper truck of internal door
- Obere Schlitten Innentür
- Carro superior puerta interna

MU 141



- Attivatore con vite
- Actvator avec vis
- Activator with screw
- Activator mit Schraube
- Activador con tornillo

MUT 92

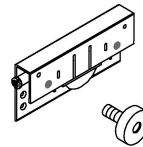

- Carrello speciale superiore anta interna con salvamaniglia
- Chariot special supérieur porte intérieure avec petit bouchon en caoutchouc d'arrêt
- Upper special truck of internal door with rubber stop
- Obere Special Schlitten Innentür mit Stopper aus Gummi zwischen den Türen
- Carro special superior puerta interna con gomita de tope

MU 145

MM 95

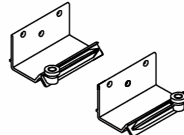

- Pattini inferiori anta esterna
- Câles inférieurs porte extérieure
- Lower sliders of external door
- Untere Laufwerk Außentür
- Patínos inferior puerta externa

MU 53 R
MU 53 L

H 17

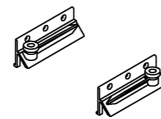

- Pattini inferiori anta interna
- Câles inférieurs porte intérieure
- Lower sliders of internal door
- Untere Laufwerk Innentür
- Patínos inferior puerta interna

MU 60 R
MU 60 L

H 17

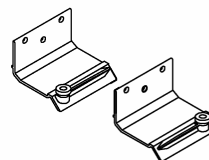

- Pattini inferiori anta esterna
- Câles inférieurs porte extérieure
- Lower sliders of external door
- Untere Laufwerk Außentür
- Patínos inferior puerta externa

MU 54 R
MU 54 L

H 33

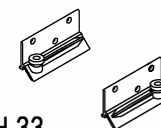

- Pattini inferiori anta interna
- Câles inférieurs porte intérieure
- Lower sliders of internal door
- Untere Laufwerk Innentür
- Patínos inferior puerta interna

MU 61 R
MU 61 L

H 33

Master Universal

peso anta - door weight 70 kg

BINARI - RAILS

ACCESSORI - ACCESSORIES



- Binario superiore
- Rail supérieur
- Upper rail
- Obere Schiene
- Carril superior

ML10

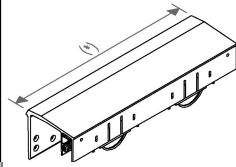

- Carrello superiore anta esterna
- Chariot supérieur porte extérieure
- Upper truck of external door
- Obere Schlitten Außentür
- Carro superior puerta externa

MU34

*misura cliente, sur mesure, made-to-measure, Maßgerecht, a medida

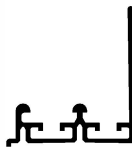

- Binario superiore
- Rail supérieur
- Upper rail
- Obere Schiene
- Carril superior

ML13

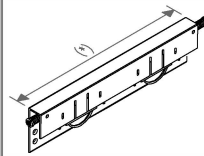

- Carrello superiore anta interna
- Chariot supérieur porte intérieure
- Upper truck of internal door
- Obere Schlitten Innentür
- Carro superior puerta interna

MU141

*misura cliente, sur mesure, made-to-measure, Maßgerecht, a medida

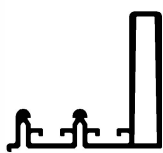

- Binario superiore
- Rail supérieur
- Upper rail
- Obere Schiene
- Carril superior

ML16

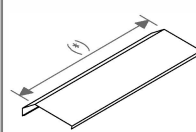

- Parapolvere superiore anta esterna
- Garde-poussière supérieur porte extérieure
- Upper dust cover of external door
- Obere Staubprofil Außentür
- Guardapolvo superior puerta externa

ML72

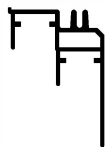

- Binario inferiore
- Rail inférieur
- Lower rail
- Untere Schiene
- Carril inferior

ML20



- Fermo superiore ammortizzato
- Arrêt supérieur amortis
- Upper amortized stopper
- Obere Stopper amortisiert
- Tope superior amortizado

MUC92SK LUXE



- Binario superiore
- Rail supérieur
- Upper rail
- Obere Schiene
- Carril superior

MQ10

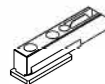

- Fermo superiore
- Arrêt supérieur
- Upper stopper
- Obere Stopper
- Tope superior

MU92

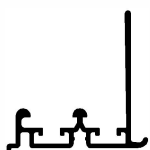

- Binario superiore
- Rail supérieur
- Upper rail
- Obere Schiene
- Carril superior

MQ13



- Clip blocco binario superiore
- Clip bloquant rail supérieur
- Upper rail hook clip
- Clip sperren Sie die obere Schiene
- Clip bloquean el carril superior

MQ910

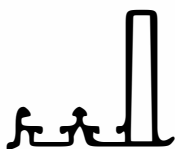

- Binario superiore
- Rail supérieur
- Upper rail
- Obere Schiene
- Carril superior

MQ16



- Clip aggancio binario superiore
- Clip rail supérieur
- Upper rail clip
- Clip obere Schiene
- Clip de superior del carril

MQ911



- Binario inferiore
- Rail inférieur
- Lower rail
- Untere Schiene
- Carril inferior

MQ20

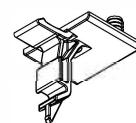

- Clip binario inferiore
- Clip rail inférieur
- Lower rail clip
- Clip untere Schiene
- Clip de inferior del carril

MQ920

Master Universal

peso anta - door weight **70 kg**

MAXI

spessore anta - door thickness **35 mm**

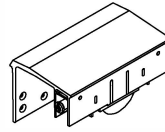
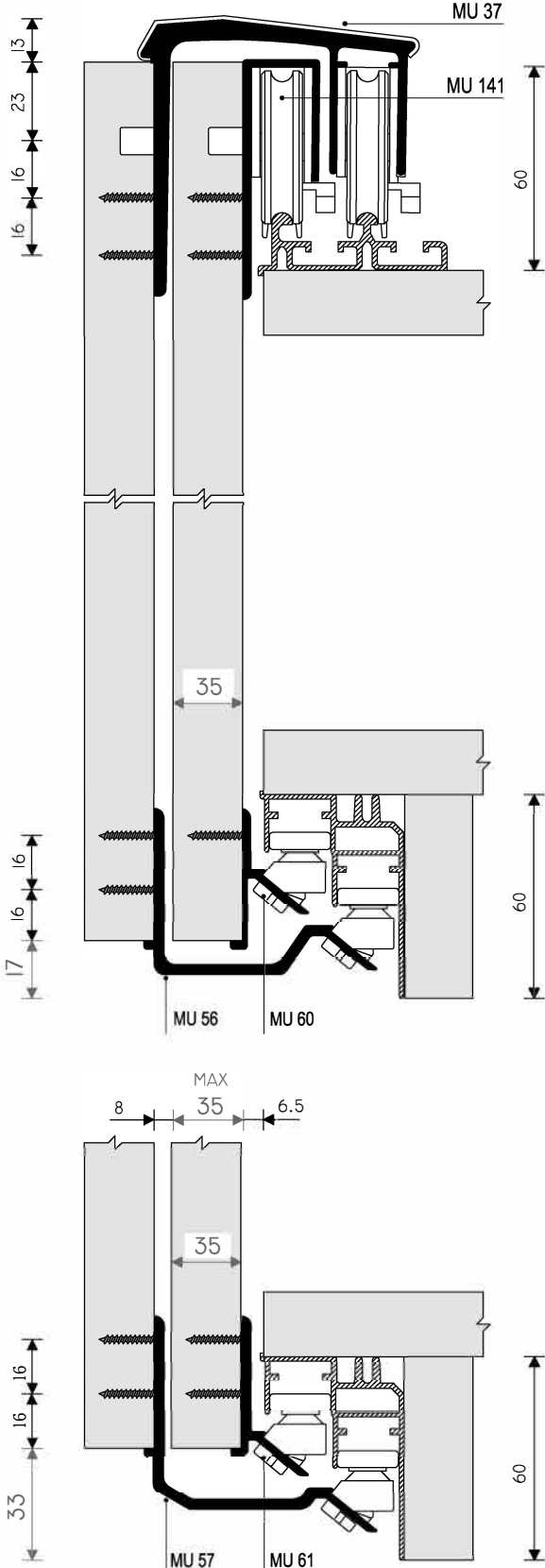

- Carrello superiore anta esterna
- Chariot supérieur porte extérieure
- Upper truck of external door
- Obere Schlitten Außentür
- Carro superior puerta externa

MU 37

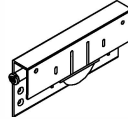

- Carrello superiore anta interna
- Chariot supérieur porte intérieure
- Upper truck of internal door
- Obere Schlitten Innentür
- Carro superior puerta interna

MU 141



- Attivatore con vite
- Actvator avec vis
- Activator with screw
- Activator mit Schraube
- Activador con tornillo

MUT 92

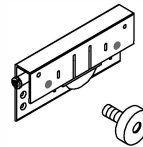

- Carrello speciale superiore anta interna con salvamaniglia
- Chariot special supérieur porte intérieure avec petit bouchon en caoutchouc d'arrêt
- Upper special truck of internal door with rubber stop
- Obere Special Schlitten Innentür mit Stopper aus Gummi zwischen den Türen
- Carro special superior puerta interna con gomita de tope

MU 145

MM 95

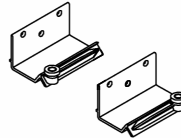

- Pattini inferiori anta esterna
- Câles inférieurs porte extérieure
- Lower sliders of external door
- Untere Laufwerk Außentür
- Patínos inferior puerta externa

MU 56 R
MU 56 L

H 17

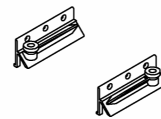

- Pattini inferiori anta interna
- Câles inférieurs porte intérieure
- Lower sliders of internal door
- Untere Laufwerk Innentür
- Patínos inferior puerta interna

MU 60 R
MU 60 L

H 17

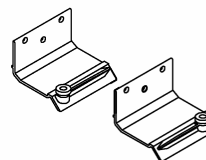

- Pattini inferiori anta esterna
- Câles inférieurs porte extérieure
- Lower sliders of external door
- Untere Laufwerk Außentür
- Patínos inferior puerta externa

MU 57 R
MU 57 L

H 33

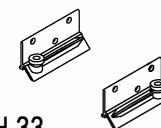

- Pattini inferiori anta interna
- Câles inférieurs porte intérieure
- Lower sliders of internal door
- Untere Laufwerk Innentür
- Patínos inferior puerta interna

MU 61 R
MU 61 L

H 33

Master Universal

peso anta - door weight **70 kg**

BINARI - RAILS

ACCESSORI - ACCESSORIES



- Binario superiore
- Rail supérieur
- Upper rail
- Obere Schiene
- Carril superior

ML10

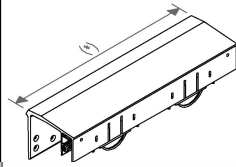

- Carrello superiore anta esterna
- Chariot supérieur porte extérieure
- Upper truck of external door
- Obere Schlitten Außentür
- Carro superior puerta externa

MU37

*misura cliente, sur mesure, made-to-measure, Maßgerecht, a medida

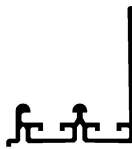

- Binario superiore
- Rail supérieur
- Upper rail
- Obere Schiene
- Carril superior

ML13

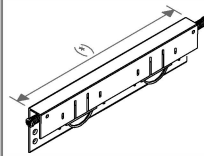

- Carrello superiore anta interna
- Chariot supérieur porte intérieure
- Upper truck of internal door
- Obere Schlitten Innentür
- Carro superior puerta interna

MU141

*misura cliente, sur mesure, made-to-measure, Maßgerecht, a medida

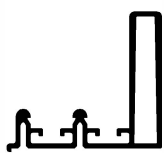

- Binario superiore
- Rail supérieur
- Upper rail
- Obere Schiene
- Carril superior

ML16

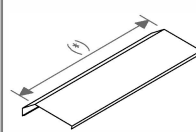

- Parapolvere superiore anta esterna
- Garde-poussière supérieur porte extérieure
- Upper dust cover of external door
- Obere Staubprofil Außentür
- Guardapolvo superior puerta externa

ML73

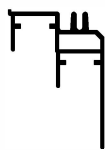

- Binario inferiore
- Rail inférieur
- Lower rail
- Untere Schiene
- Carril inferior

ML20



- Fermo superiore ammortizzato
- Arrêt supérieur amortis
- Upper amortized stopper
- Obere Stopper amortisiert
- Tope superior amortizado

MUC92SK LUXE



- Binario superiore
- Rail supérieur
- Upper rail
- Obere Schiene
- Carril superior

MQ10

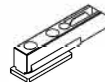

- Fermo superiore
- Arrêt supérieur
- Upper stopper
- Obere Stopper
- Tope superior

MU92

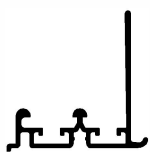

- Binario superiore
- Rail supérieur
- Upper rail
- Obere Schiene
- Carril superior

MQ13



- Clip blocco binario superiore
- Clip bloquant rail supérieur
- Upper rail hook clip
- Clip sperren Sie die obere Schiene
- Clip bloquean el carril superior

MQ910

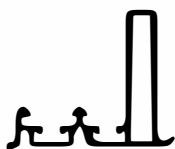

- Binario superiore
- Rail supérieur
- Upper rail
- Obere Schiene
- Carril superior

MQ16



- Clip aggancio binario superiore
- Clip rail supérieur
- Upper rail clip
- Clip obere Schiene
- Clip de superior del carril

MQ911



- Binario inferiore
- Rail inférieur
- Lower rail
- Untere Schiene
- Carril inferior

MQ20

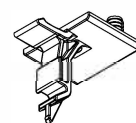

- Clip binario inferiore
- Clip rail inférieur
- Lower rail clip
- Clip untere Schiene
- Clip de inferior del carril

MQ920

Master Universal

peso anta - door weight **70 kg**

EXTRA

spessore anta - door thickness **50 mm**

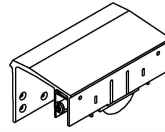
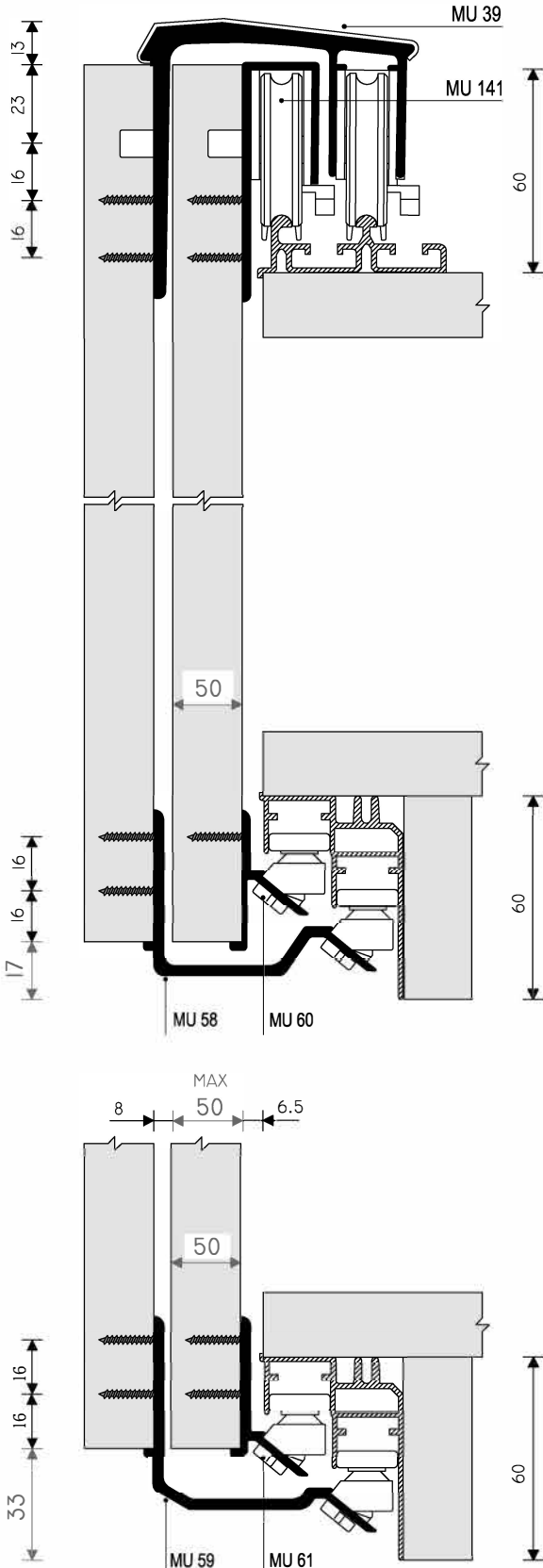

- Carrello superiore anta esterna
- Chariot supérieur porte extérieure
- Upper truck of external door
- Obere Schlitten Außentür
- Carro superior puerta externa

MU 39

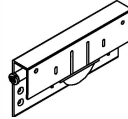

- Carrello superiore anta interna
- Chariot supérieur porte intérieure
- Upper truck of internal door
- Obere Schlitten Innentür
- Carro superior puerta interna

MU 141



- Attivatore con vite
- Actvator avec vis
- Activator with screw
- Activator mit Schraube
- Activador con tornillo

MUT 92

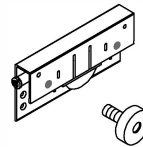

- Carrello speciale superiore anta interna con salvamaniglia
- Chariot special supérieur porte intérieure avec petit bouchon en caoutchouc d'arrêt
- Upper special truck of internal door with rubber stop
- Obere Special Schlitten Innentür mit Stopper aus Gummi zwischen den Türen
- Carro special superior puerta interna con gomita de tope

MU 145

MM 95

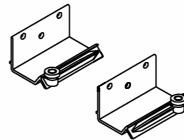

- Pattini inferiori anta esterna
- Câles inférieurs porte extérieure
- Lower sliders of external door
- Untere Laufwerk Außentür
- Patínos inferior puerta externa

MU 58 R
MU 58 L

H 17

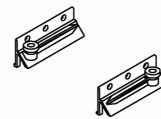

- Pattini inferiori anta interna
- Câles inférieurs porte intérieure
- Lower sliders of internal door
- Untere Laufwerk Innentür
- Patínos inferior puerta interna

MU 60 R
MU 60 L

H 17

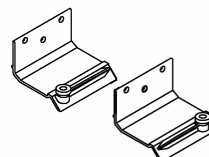

- Pattini inferiori anta esterna
- Câles inférieurs porte extérieure
- Lower sliders of external door
- Untere Laufwerk Außentür
- Patínos inferior puerta externa

MU 59 R
MU 59 L

H 33

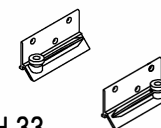

- Pattini inferiori anta interna
- Câles inférieurs porte intérieure
- Lower sliders of internal door
- Untere Laufwerk Innentür
- Patínos inferior puerta interna

MU 61 R
MU 61 L

H 33

Master Universal

peso anta - door weight **70 kg**

BINARI - RAILS

ACCESSORI - ACCESSORIES



- Binario superiore
- Rail supérieur
- Upper rail
- Obere Schiene
- Carril superior

ML10

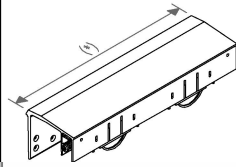

- Carrello superiore anta esterna
- Chariot supérieur porte extérieure
- Upper truck of external door
- Obere Schlitten Außentür
- Carro superior puerta externa

MU39

*misura cliente, sur mesure, made-to-measure, Maßgerecht, a medida

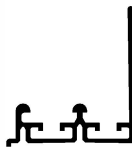

- Binario superiore
- Rail supérieur
- Upper rail
- Obere Schiene
- Carril superior

ML13

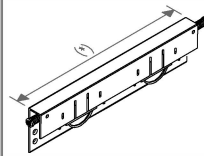

- Carrello superiore anta interna
- Chariot supérieur porte intérieure
- Upper truck of internal door
- Obere Schlitten Innentür
- Carro superior puerta interna

MU141

*misura cliente, sur mesure, made-to-measure, Maßgerecht, a medida

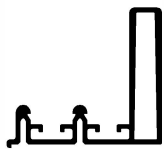

- Binario superiore
- Rail supérieur
- Upper rail
- Obere Schiene
- Carril superior

ML16

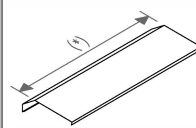

- Parapolvere superiore anta esterna
- Garde-poussière supérieur porte extérieure
- Upper dust cover of external door
- Obere Staubprofil Außentür
- Guardapolvo superior puerta externa

ML75

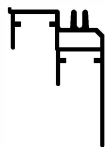

- Binario inferiore
- Rail inférieur
- Lower rail
- Untere Schiene
- Carril inferior

ML20



- Fermo superiore ammortizzato
- Arrêt supérieur amortis
- Upper amortized stopper
- Obere Stopper amortisiert
- Tope superior amortizado

MUC92SK LUXE



- Binario superiore
- Rail supérieur
- Upper rail
- Obere Schiene
- Carril superior

MQ10

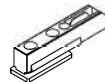

- Fermo superiore
- Arrêt supérieur
- Upper stopper
- Obere Stopper
- Tope superior

MU92

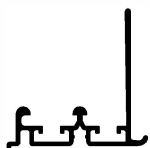

- Binario superiore
- Rail supérieur
- Upper rail
- Obere Schiene
- Carril superior

MQ13



- Clip blocco binario superiore
- Clip bloquant rail supérieur
- Upper rail hook clip
- Clip sperren Sie die obere Schiene
- Clip bloquean el carril superior

MQ910

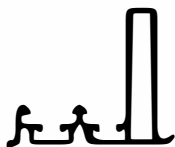

- Binario superiore
- Rail supérieur
- Upper rail
- Obere Schiene
- Carril superior

MQ16



- Clip aggancio binario superiore
- Clip rail supérieur
- Upper rail clip
- Clip obere Schiene
- Clip de superior del carril

MQ911

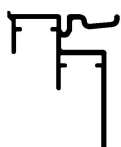

- Binario inferiore
- Rail inférieur
- Lower rail
- Untere Schiene
- Carril inferior

MQ20

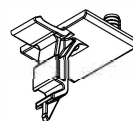

- Clip binario inferiore
- Clip rail inférieur
- Lower rail clip
- Clip untere Schiene
- Clip de inferior del carril

MQ920

Master Universal

peso anta - door weight max 100 kg

MINI STRONG

spessore anta - door thickness max 23 mm

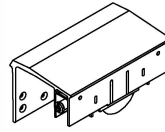
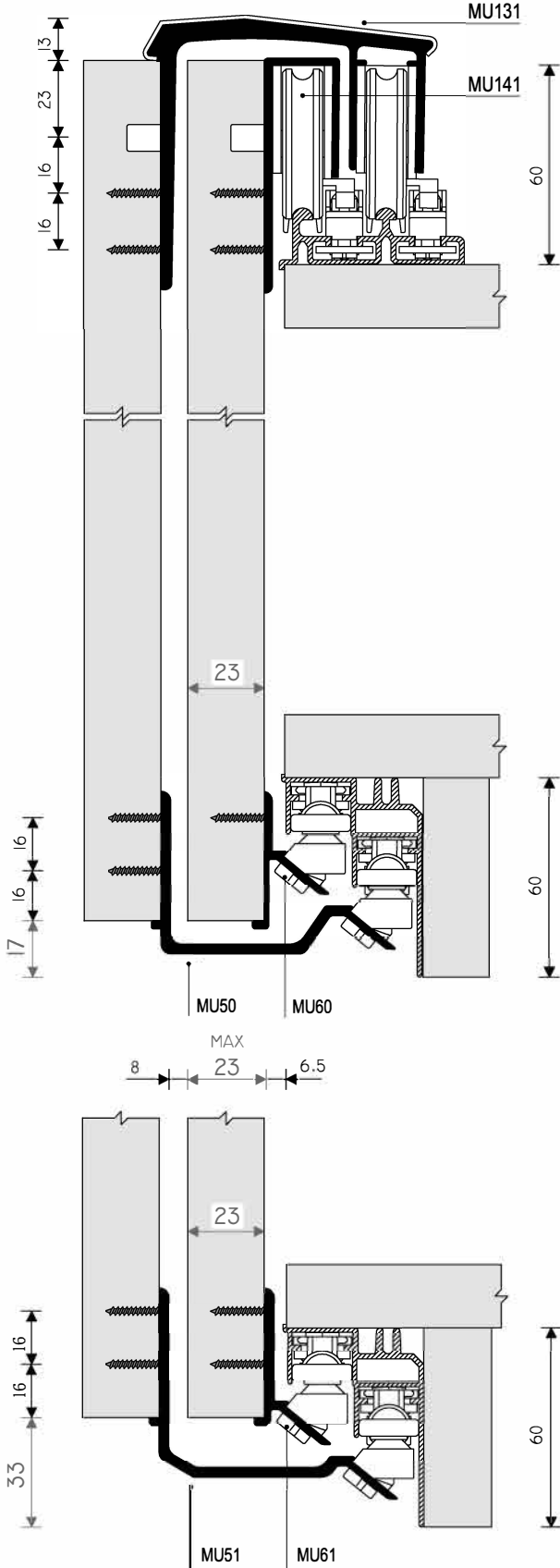

- Carrello superiore anta esterna
- Chariot supérieur porte extérieure
- Upper truck of external door
- Obere Schlitten Außentür
- Carro superior puerta externa

MU 131

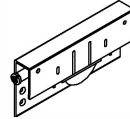

- Carrello superiore anta interna
- Chariot supérieur porte intérieure
- Upper truck of internal door
- Obere Schlitten Innentür
- Carro superior puerta interna

MU 141



- Attivatore con vite
- Activator avec vis
- Activator with screw
- Activator mit Schraube
- Activador con tornillo

MUT 92

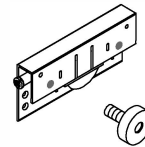

- Carrello speciale superiore anta interna con salvamaniglia
- Chariot special supérieur porte intérieure avec petit bouchon en caoutchouc d'arrêt
- Upper special truck of internal door with rubber stop
- Obere Special Schlitten Innentür mit Stopper aus Gummi zwischen den Türen
- Carro special superior puerta interna con gomita de tope

MU 145

MM 95

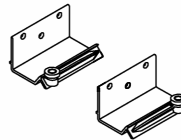

- Pattini inferiori anta esterna
- Câles inférieurs porte extérieure
- Lower sliders of external door
- Untere Laufwerk Außentür
- Patínos inferior puerta externa

MU 50 R
MU 50 L

H 17

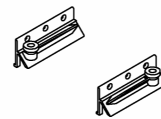

- Pattini inferiori anta interna
- Câles inférieurs porte intérieure
- Lower sliders of internal door
- Untere Laufwerk Innentür
- Patínos inferior puerta interna

MU 60 R
MU 60 L

H 17

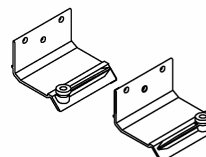

- Pattini inferiori anta esterna
- Câles inférieurs porte extérieure
- Lower sliders of external door
- Untere Laufwerk Außentür
- Patínos inferior puerta externa

MU 51 R
MU 51 L

H 33

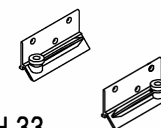

- Pattini inferiori anta interna
- Câles inférieurs porte intérieure
- Lower sliders of internal door
- Untere Laufwerk Innentür
- Patínos inferior puerta interna

MU 61 R
MU 61 L

H 33

Master Universal

peso anta - door weight max 100 kg

BINARI - RAILS

ACCESSORI - ACCESSORIES



- Binario superiore
- Rail supérieur
- Upper rail
- Obere Schiene
- Carril superior

ML10

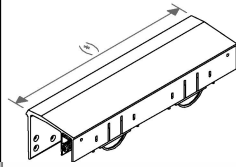

- Carrello superiore anta esterna
- Chariot supérieur porte extérieure
- Upper truck of external door
- Obere Schlitten Außentür
- Carro superior puerta externa

MU131

*misura cliente, sur mesure, made-to-measure, Maßgerecht, a medida

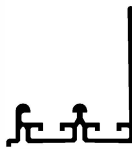

- Binario superiore
- Rail supérieur
- Upper rail
- Obere Schiene
- Carril superior

ML13

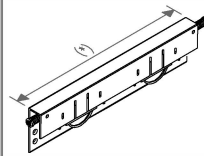

- Carrello superiore anta interna
- Chariot supérieur porte intérieure
- Upper truck of internal door
- Obere Schlitten Innentür
- Carro superior puerta interna

MU141

*misura cliente, sur mesure, made-to-measure, Maßgerecht, a medida

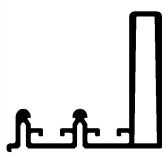

- Binario superiore
- Rail supérieur
- Upper rail
- Obere Schiene
- Carril superior

ML16

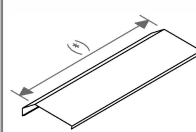

- Parapolvere superiore anta esterna
- Garde-poussière supérieur porte extérieure
- Upper dust cover of external door
- Obere Staubprofil Außentür
- Guardapolvo superior puerta externa

ML170

*misura cliente, sur mesure, made-to-measure, Maßgerecht, a medida

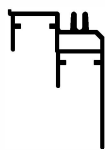

- Binario inferiore
- Rail inférieur
- Lower rail
- Untere Schiene
- Carril inferior

ML20



- Fermo superiore ammortizzato
- Arrêt supérieur amortis
- Upper amortized stopper
- Obere Stopper amortisiert
- Tope superior amortizado

MUC92SK LUXE



- Binario superiore
- Rail supérieur
- Upper rail
- Obere Schiene
- Carril superior

MQ10

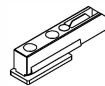

- Fermo superiore
- Arrêt supérieur
- Upper stopper
- Obere Stopper
- Tope superior

MU92

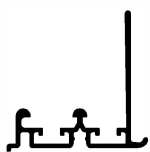

- Binario superiore
- Rail supérieur
- Upper rail
- Obere Schiene
- Carril superior

MQ13



- Clip blocco binario superiore
- Clip bloquant rail supérieur
- Upper rail hook clip
- Clip sperren Sie die obere Schiene
- Clip bloquean el carril superior

MQ910

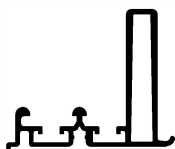

- Binario superiore
- Rail supérieur
- Upper rail
- Obere Schiene
- Carril superior

MQ16



- Clip aggancio binario superiore
- Clip rail supérieur
- Upper rail clip
- Clip obere Schiene
- Clip de superior del carril

MQ911

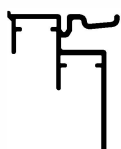

- Binario inferiore
- Rail inférieur
- Lower rail
- Untere Schiene
- Carril inferior

MQ20

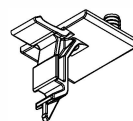

- Clip binario inferiore
- Clip rail inférieur
- Lower rail clip
- Clip untere Schiene
- Clip de inferior del carril

MQ920

Master Universal

peso anta - door weight **100 kg**

MIDI STRONG

spessore anta - door thickness **30 mm**

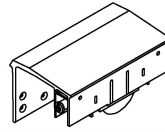
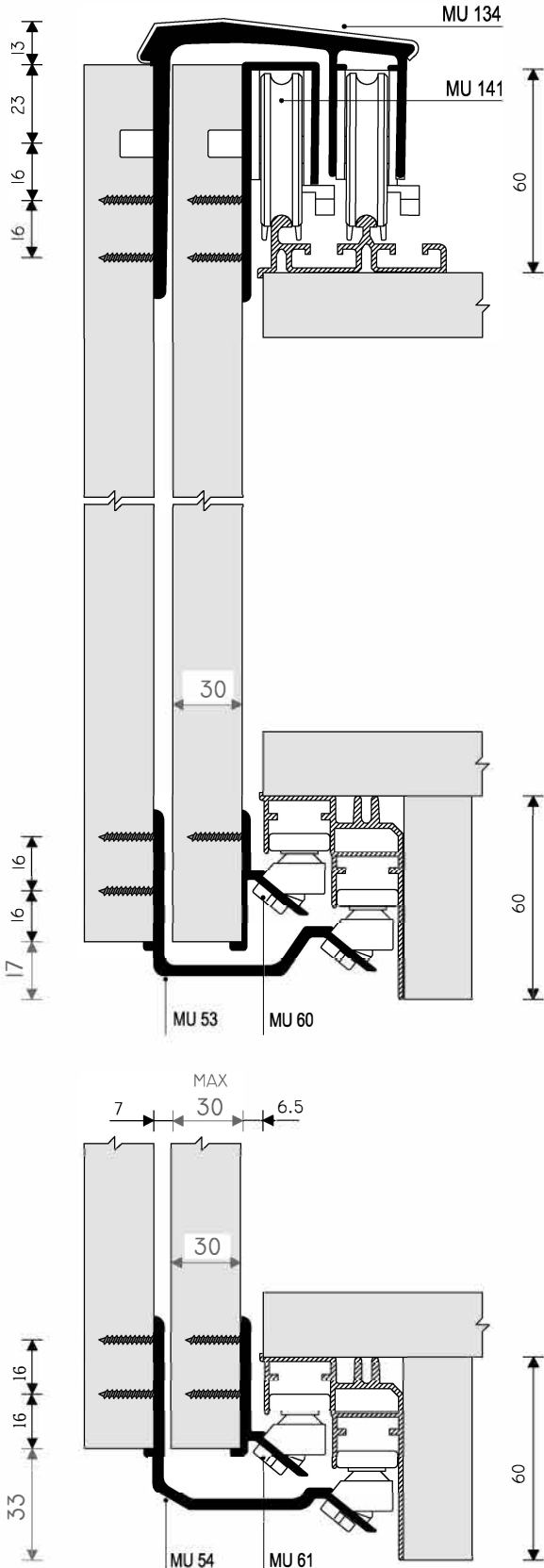

- Carrello superiore anta esterna
- Chariot supérieur porte extérieure
- Upper truck of external door
- Obere Schlitten Außentür
- Carro superior puerta externa

MU 134

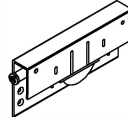

- Carrello superiore anta interna
- Chariot supérieur porte intérieure
- Upper truck of internal door
- Obere Schlitten Innentür
- Carro superior puerta interna

MU 141



- Attivatore con vite
- Activator avec vis
- Activator with screw
- Activator mit Schraube
- Activador con tornillo

MUT 92

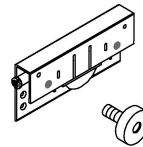

- Carrello speciale superiore anta interna con salvamaniglia
- Chariot special supérieur porte intérieure avec petit bouchon en caoutchouc d'arrêt
- Upper special truck of internal door with rubber stop
- Obere Special Schlitten Innentür mit Stopper aus Gummi zwischen den Türen
- Carro special superior puerta interna con gomita de tope

MU 145

MM 95

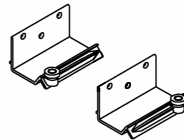

- Pattini inferiori anta esterna
- Câles inférieurs porte extérieure
- Lower sliders of external door
- Untere Laufwerk Außentür
- Patínos inferior puerta externa

MU 53 R
MU 53 L

H 17

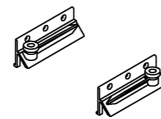

- Pattini inferiori anta interna
- Câles inférieurs porte intérieure
- Lower sliders of internal door
- Untere Laufwerk Innentür
- Patínos inferior puerta interna

MU 60 R
MU 60 L

H 17

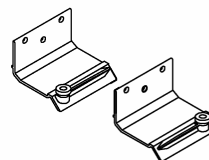

- Pattini inferiori anta esterna
- Câles inférieurs porte extérieure
- Lower sliders of external door
- Untere Laufwerk Außentür
- Patínos inferior puerta externa

MU 54 R
MU 54 L

H 33

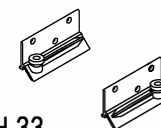

- Pattini inferiori anta interna
- Câles inférieurs porte intérieure
- Lower sliders of internal door
- Untere Laufwerk Innentür
- Patínos inferior puerta interna

MU 61 R
MU 61 L

H 33

Master Universal

peso anta - door weight **100 kg**

BINARI - RAILS

ACCESSORI - ACCESSORIES



- Binario superiore
- Rail supérieur
- Upper rail
- Obere Schiene
- Carril superior

ML10

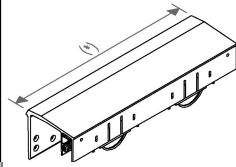

- Carrello superiore anta esterna
- Chariot supérieur porte extérieure
- Upper truck of external door
- Obere Schlitten Außentür
- Carro superior puerta externa

MU134

*misura cliente, sur mesure, made-to-measure, Maßgerecht, a medida

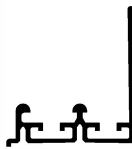

- Binario superiore
- Rail supérieur
- Upper rail
- Obere Schiene
- Carril superior

ML13

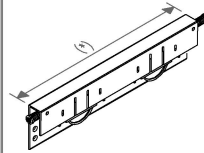

- Carrello superiore anta interna
- Chariot supérieur porte intérieure
- Upper truck of internal door
- Obere Schlitten Innentür
- Carro superior puerta interna

MU141

*misura cliente, sur mesure, made-to-measure, Maßgerecht, a medida

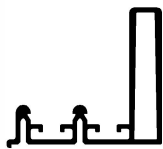

- Binario superiore
- Rail supérieur
- Upper rail
- Obere Schiene
- Carril superior

ML16

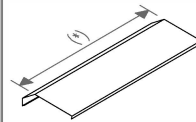

- Parapolvere superiore anta esterna
- Garde-poussière supérieur porte extérieure
- Upper dust cover of external door
- Obere Staubprofil Außentür
- Guardapolvo superior puerta externa

ML172

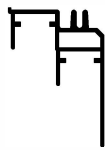

- Binario inferiore
- Rail inférieur
- Lower rail
- Untere Schiene
- Carril inferior

ML20



- Fermo superiore ammortizzato
- Arrêt supérieur amortis
- Upper amortized stopper
- Obere Stopper amortisiert
- Tope superior amortizado

MUC92SK LUXE



- Binario superiore
- Rail supérieur
- Upper rail
- Obere Schiene
- Carril superior

MQ10

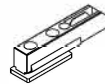

- Fermo superiore
- Arrêt supérieur
- Upper stopper
- Obere Stopper
- Tope superior

MU92

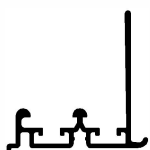

- Binario superiore
- Rail supérieur
- Upper rail
- Obere Schiene
- Carril superior

MQ13



- Clip blocco binario superiore
- Clip bloquant rail supérieur
- Upper rail hook clip
- Clip sperren Sie die obere Schiene
- Clip bloquean el carril superior

MQ910

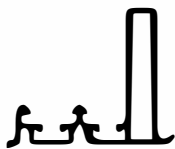

- Binario superiore
- Rail supérieur
- Upper rail
- Obere Schiene
- Carril superior

MQ16



- Clip aggancio binario superiore
- Clip rail supérieur
- Upper rail clip
- Clip obere Schiene
- Clip de superior del carril

MQ911

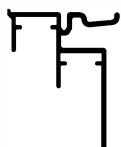

- Binario inferiore
- Rail inférieur
- Lower rail
- Untere Schiene
- Carril inferior

MQ20

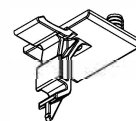

- Clip binario inferiore
- Clip rail inférieur
- Lower rail clip
- Clip untere Schiene
- Clip de inferior del carril

MQ920

Master Universal

peso anta - door weight **100 kg**

MAXI STRONG

spessore anta - door thickness **35 mm**

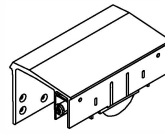
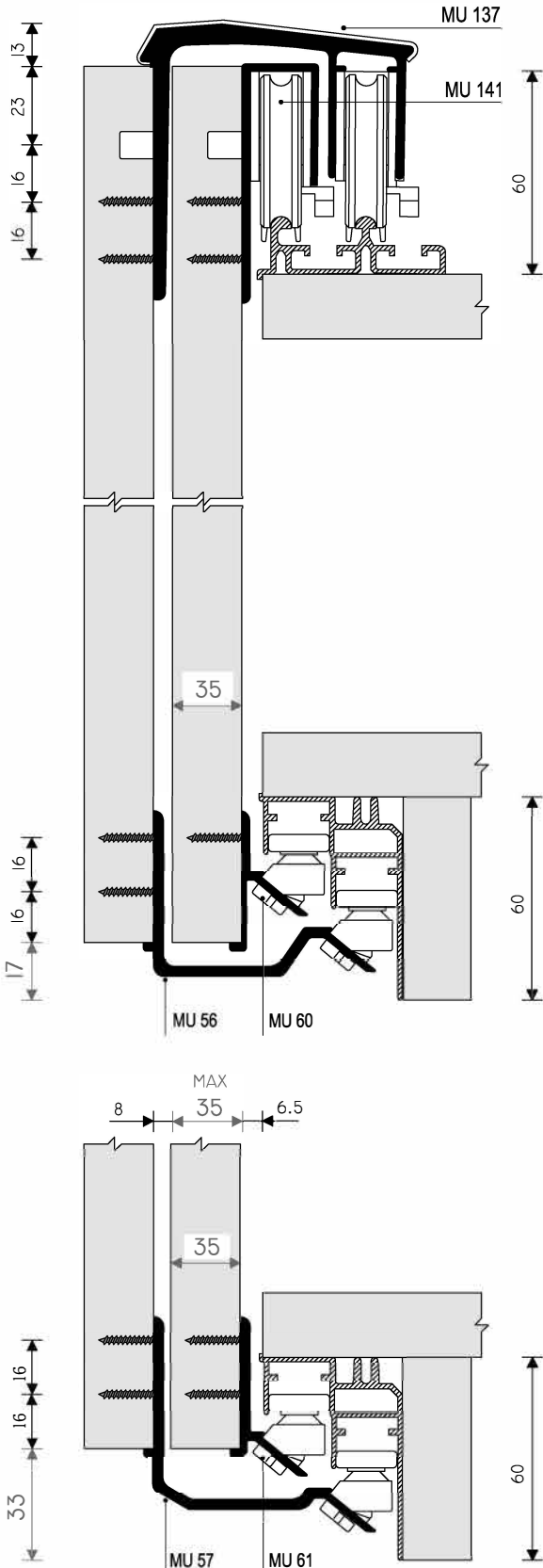

- Carrello superiore anta esterna
- Chariot supérieur porte extérieure
- Upper truck of external door
- Obere Schlitten Außentür
- Carro superior puerta externa

MU 137

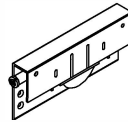

- Carrello superiore anta interna
- Chariot supérieur porte intérieure
- Upper truck of internal door
- Obere Schlitten Innentür
- Carro superior puerta interna

MU 141



- Attivatore con vite
- Activator avec vis
- Activator with screw
- Activator mit Schraube
- Activador con tornillo

MUT 92

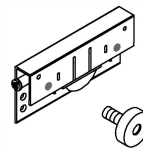

- Carrello speciale superiore anta interna con salvamaniglia
- Chariot special supérieur porte intérieure avec petit bouchon en caoutchouc d'arrêt
- Upper special truck of internal door with rubber stop
- Obere Special Schlitten Innentür mit Stopper aus Gummi zwischen den Türen
- Carro special superior puerta interna con gomita de tope

MU 145

MM 95

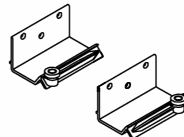

- Pattini inferiori anta esterna
- Câles inférieurs porte extérieure
- Lower sliders of external door
- Untere Laufwerk Außentür
- Patinos inferior puerta externa

MU 56 R
MU 56 L

H 17

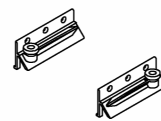

- Pattini inferiori anta interna
- Câles inférieurs porte intérieure
- Lower sliders of internal door
- Untere Laufwerk Innentür
- Patinos inferior puerta interna

MU 60 R
MU 60 L

H 17

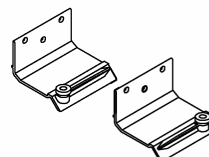

- Pattini inferiori anta esterna
- Câles inférieurs porte extérieure
- Lower sliders of external door
- Untere Laufwerk Außentür
- Patinos inferior puerta externa

MU 57 R
MU 57 L

H 33

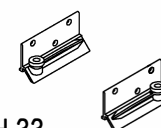

- Pattini inferiori anta interna
- Câles inférieurs porte intérieure
- Lower sliders of internal door
- Untere Laufwerk Innentür
- Patinos inferior puerta interna

MU 61 R
MU 61 L

H 33

Master Universal

peso anta - door weight **100 kg**

BINARI - RAILS

ACCESSORI - ACCESSORIES



- Binario superiore
- Rail supérieur
- Upper rail
- Obere Schiene
- Carril superior

ML10

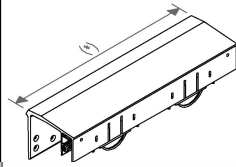

- Carrello superiore anta esterna
- Chariot supérieur porte extérieure
- Upper truck of external door
- Obere Schlitten Außentür
- Carro superior puerta externa

MU137

*misura cliente, sur mesure, made-to-measure, Maßgerecht, a medida

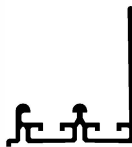

- Binario superiore
- Rail supérieur
- Upper rail
- Obere Schiene
- Carril superior

ML13

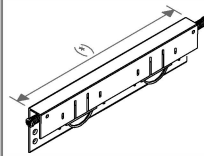

- Carrello superiore anta interna
- Chariot supérieur porte intérieure
- Upper truck of internal door
- Obere Schlitten Innentür
- Carro superior puerta interna

MU141

*misura cliente, sur mesure, made-to-measure, Maßgerecht, a medida

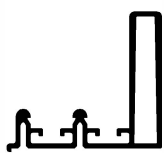

- Binario superiore
- Rail supérieur
- Upper rail
- Obere Schiene
- Carril superior

ML16

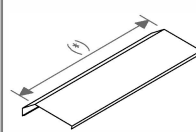

- Parapolvere superiore anta esterna
- Garde-poussière supérieur porte extérieure
- Upper dust cover of external door
- Obere Staubprofil Außentür
- Guardapolvo superior puerta externa

ML173

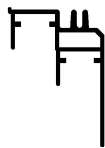

- Binario inferiore
- Rail inférieur
- Lower rail
- Untere Schiene
- Carril inferior

ML20



- Fermo superiore ammortizzato
- Arrêt supérieur amortis
- Upper amortized stopper
- Obere Stopper amortisiert
- Tope superior amortizado

MUC92SK LUXE



- Binario superiore
- Rail supérieur
- Upper rail
- Obere Schiene
- Carril superior

MQ10

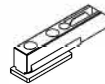

- Fermo superiore
- Arrêt supérieur
- Upper stopper
- Obere Stopper
- Tope superior

MU92

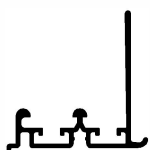

- Binario superiore
- Rail supérieur
- Upper rail
- Obere Schiene
- Carril superior

MQ13



- Clip blocco binario superiore
- Clip bloquant rail supérieur
- Upper rail hook clip
- Clip sperren Sie die obere Schiene
- Clip bloquean el carril superior

MQ910

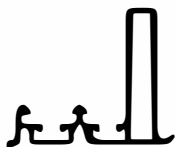

- Binario superiore
- Rail supérieur
- Upper rail
- Obere Schiene
- Carril superior

MQ16



- Clip aggancio binario superiore
- Clip rail supérieur
- Upper rail clip
- Clip obere Schiene
- Clip de superior del carril

MQ911

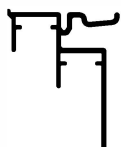

- Binario inferiore
- Rail inférieur
- Lower rail
- Untere Schiene
- Carril inferior

MQ20

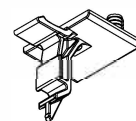

- Clip binario inferiore
- Clip rail inférieur
- Lower rail clip
- Clip untere Schiene
- Clip de inferior del carril

MQ920

Master Universal

peso anta - door weight **100 kg**

SUPER MAXI STRONG

spessore anta - door thickness **40 mm**

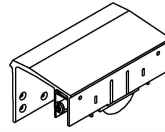
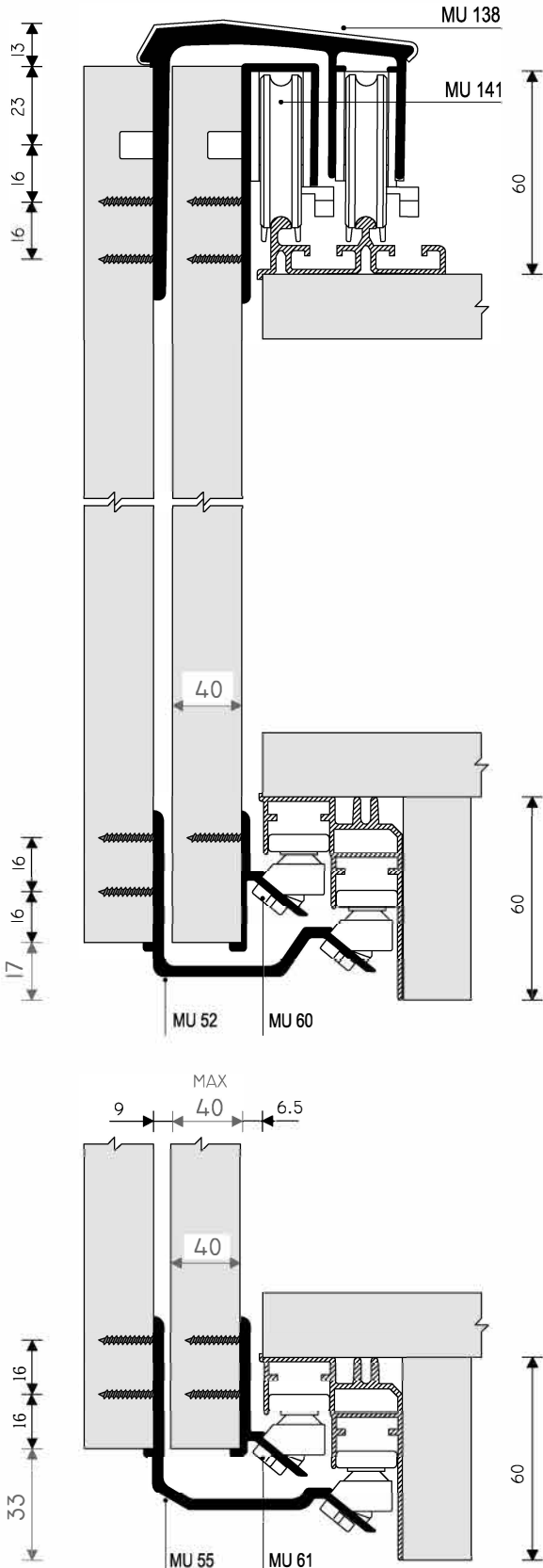

- Carrello superiore anta esterna
- Chariot supérieur porte extérieure
- Upper truck of external door
- Obere Schlitten Außentür
- Carro superior puerta externa

MU 138

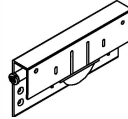

- Carrello superiore anta interna
- Chariot supérieur porte intérieure
- Upper truck of internal door
- Obere Schlitten Innentür
- Carro superior puerta interna

MU 141



- Attivatore con vite
- Activator avec vis
- Activator with screw
- Activator mit Schraube
- Activador con tornillo

MUT 92

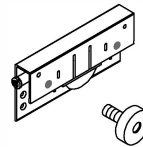

- Carrello speciale superiore anta interna con salvamaniglia
- Chariot special supérieur porte intérieure avec petit bouchon en caoutchouc d'arrêt
- Upper special truck of internal door with rubber stop
- Obere Special Schlitten Innentür mit Stopper aus Gummi zwischen den Türen
- Carro special superior puerta interna con gomita de tope

MU 145

MM 95

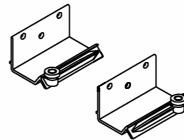

- Pattini inferiori anta esterna
- Câles inférieurs porte extérieure
- Lower sliders of external door
- Untere Laufwerk Außentür
- Patínos inferior puerta externa

MU 52 R
MU 52 L

H 17

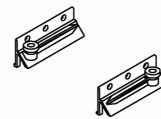

- Pattini inferiori anta interna
- Câles inférieurs porte intérieure
- Lower sliders of internal door
- Untere Laufwerk Innentür
- Patínos inferior puerta interna

MU 60 R
MU 60 L

H 17

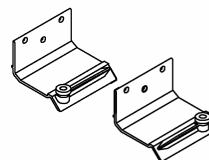

- Pattini inferiori anta esterna
- Câles inférieurs porte extérieure
- Lower sliders of external door
- Untere Laufwerk Außentür
- Patínos inferior puerta externa

MU 55 R
MU 55 L

H 33

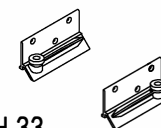

- Pattini inferiori anta interna
- Câles inférieurs porte intérieure
- Lower sliders of internal door
- Untere Laufwerk Innentür
- Patínos inferior puerta interna

MU 61 R
MU 61 L

H 33

Master Universal

peso anta - door weight **100 kg**

BINARI - RAILS

ACCESSORI - ACCESSORIES



- Binario superiore
- Rail supérieur
- Upper rail
- Obere Schiene
- Carril superior

ML10

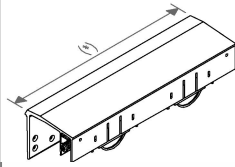

- Carrello superiore anta esterna
- Chariot supérieur porte extérieure
- Upper truck of external door
- Obere Schlitten Außentür
- Carro superior puerta externa

MU138

*misura cliente, sur mesure, made-to-measure, Maßgerecht, a medida

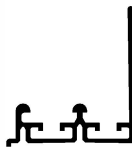

- Binario superiore
- Rail supérieur
- Upper rail
- Obere Schiene
- Carril superior

ML13

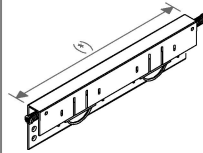

- Carrello superiore anta interna
- Chariot supérieur porte intérieure
- Upper truck of internal door
- Obere Schlitten Innentür
- Carro superior puerta interna

MU141

*misura cliente, sur mesure, made-to-measure, Maßgerecht, a medida

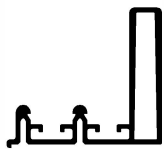

- Binario superiore
- Rail supérieur
- Upper rail
- Obere Schiene
- Carril superior

ML16

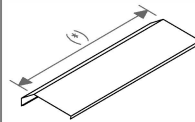

- Parapolvere superiore anta esterna
- Garde-poussière supérieur porte extérieure
- Upper dust cover of external door
- Obere Staubprofil Außentür
- Guardapolvo superior puerta externa

ML174

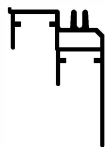

- Binario inferiore
- Rail inférieur
- Lower rail
- Untere Schiene
- Carril inferior

ML20



- Fermo superiore ammortizzato
- Arrêt supérieur amortis
- Upper amortized stopper
- Obere Stopper amortisiert
- Tope superior amortizado

MUC92SK LUXE



- Binario superiore
- Rail supérieur
- Upper rail
- Obere Schiene
- Carril superior

MQ10

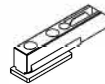

- Fermo superiore
- Arrêt supérieur
- Upper stopper
- Obere Stopper
- Tope superior

MU92

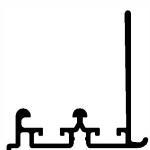

- Binario superiore
- Rail supérieur
- Upper rail
- Obere Schiene
- Carril superior

MQ13



- Clip blocco binario superiore
- Clip bloquant rail supérieur
- Upper rail hook clip
- Clip sperren Sie die obere Schiene
- Clip bloquean el carril superior

MQ910

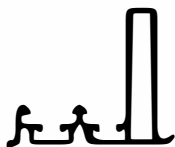

- Binario superiore
- Rail supérieur
- Upper rail
- Obere Schiene
- Carril superior

MQ16



- Clip aggancio binario superiore
- Clip rail supérieur
- Upper rail clip
- Clip obere Schiene
- Clip de superior del carril

MQ911

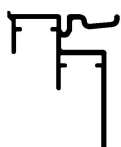

- Binario inferiore
- Rail inférieur
- Lower rail
- Untere Schiene
- Carril inferior

MQ20

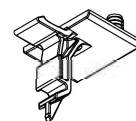

- Clip binario inferiore
- Clip rail inférieur
- Lower rail clip
- Clip untere Schiene
- Clip de inferior del carril

MQ920

Master Universal

peso anta - door weight **100 kg**

EXTRA STRONG

spessore anta - door thickness **50 mm**

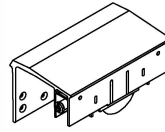
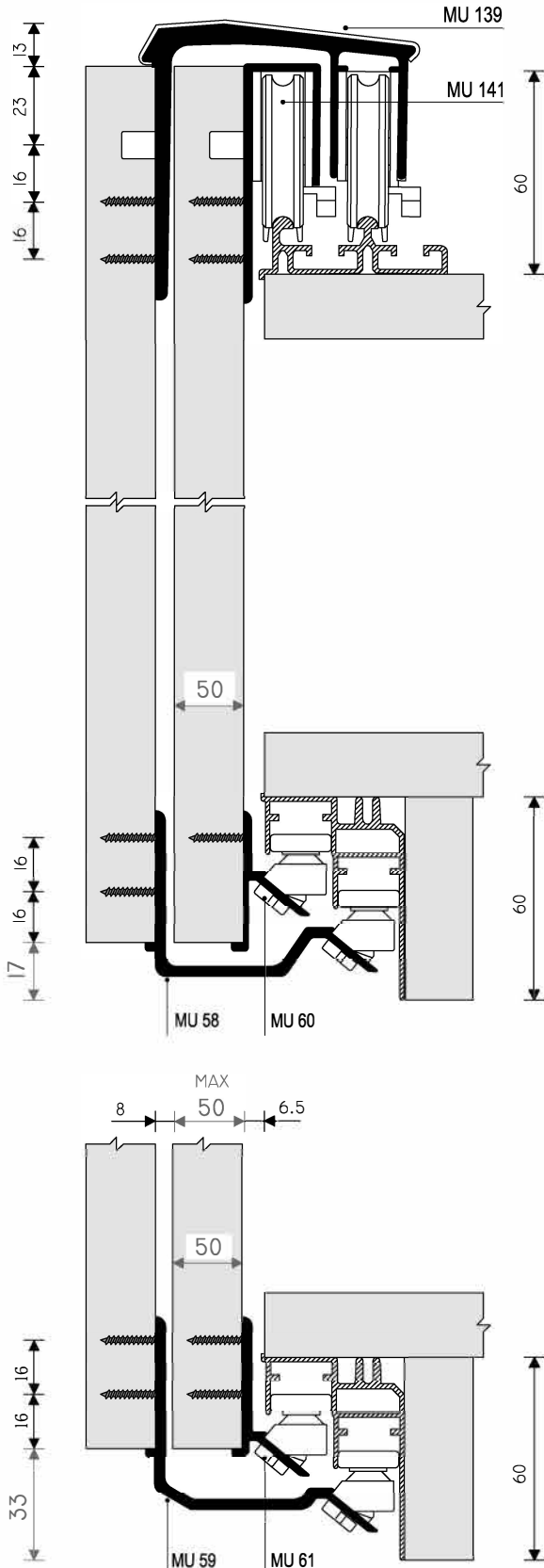

- Carrello superiore anta esterna
- Chariot supérieur porte extérieure
- Upper truck of external door
- Obere Schlitten Außentür
- Carro superior puerta externa

MU 139

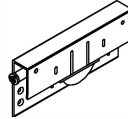

- Carrello superiore anta interna
- Chariot supérieur porte intérieure
- Upper truck of internal door
- Obere Schlitten Innentür
- Carro superior puerta interna

MU 141



- Attivatore con vite
- Activator avec vis
- Activator with screw
- Activator mit Schraube
- Activador con tornillo

MUT 92

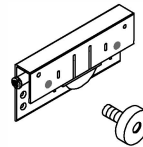

- Carrello speciale superiore anta interna con salvamaniglia
- Chariot special supérieur porte intérieure avec petit bouchon en caoutchouc d'arrêt
- Upper special truck of internal door with rubber stop
- Obere Special Schlitten Innentür mit Stopper aus Gummi zwischen den Türen
- Carro special superior puerta interna con gomita de tope

MU 145

MM 95

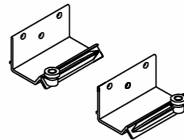

- Pattini inferiori anta esterna
- Câles inférieurs porte extérieure
- Lower sliders of external door
- Untere Laufwerk Außentür
- Patínos inferior puerta externa

MU 58 R
MU 58 L

H 17

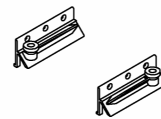

- Pattini inferiori anta interna
- Câles inférieurs porte intérieure
- Lower sliders of internal door
- Untere Laufwerk Innentür
- Patínos inferior puerta interna

MU 60 R
MU 60 L

H 17

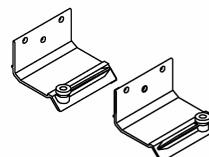

- Pattini inferiori anta esterna
- Câles inférieurs porte extérieure
- Lower sliders of external door
- Untere Laufwerk Außentür
- Patínos inferior puerta externa

MU 59 R
MU 59 L

H 33

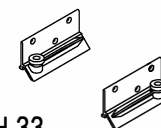

- Pattini inferiori anta interna
- Câles inférieurs porte intérieure
- Lower sliders of internal door
- Untere Laufwerk Innentür
- Patínos inferior puerta interna

MU 61 R
MU 61 L

H 33

Master Universal

peso anta - door weight **100 kg**

BINARI - RAILS

ACCESSORI - ACCESSORIES



- Binario superiore
- Rail supérieur
- Upper rail
- Obere Schiene
- Carril superior

ML10

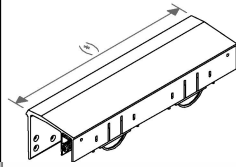

- Carrello superiore anta esterna
- Chariot supérieur porte extérieure
- Upper truck of external door
- Obere Schlitten Außentür
- Carro superior puerta externa

MU139

*misura cliente, sur mesure, made-to-measure, Maßgerecht, a medida

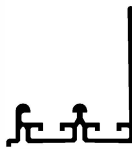

- Binario superiore
- Rail supérieur
- Upper rail
- Obere Schiene
- Carril superior

ML13

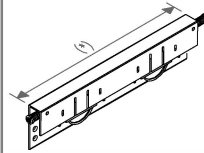

- Carrello superiore anta interna
- Chariot supérieur porte intérieure
- Upper truck of internal door
- Obere Schlitten Innentür
- Carro superior puerta interna

MU141

*misura cliente, sur mesure, made-to-measure, Maßgerecht, a medida

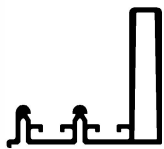

- Binario superiore
- Rail supérieur
- Upper rail
- Obere Schiene
- Carril superior

ML16

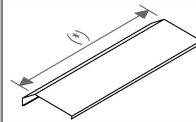

- Parapolvere superiore anta esterna
- Garde-poussière supérieur porte extérieure
- Upper dust cover of external door
- Obere Staubprofil Außentür
- Guardapolvo superior puerta externa

ML175

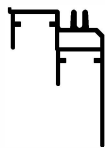

- Binario inferiore
- Rail inférieur
- Lower rail
- Untere Schiene
- Carril inferior

ML20



- Fermo superiore ammortizzato
- Arrêt supérieur amortis
- Upper amortized stopper
- Obere Stopper amortisiert
- Tope superior amortizado

MUC92SK LUXE



- Binario superiore
- Rail supérieur
- Upper rail
- Obere Schiene
- Carril superior

MQ10

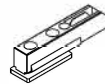

- Fermo superiore
- Arrêt supérieur
- Upper stopper
- Obere Stopper
- Tope superior

MU92

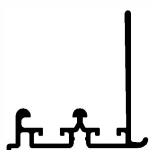

- Binario superiore
- Rail supérieur
- Upper rail
- Obere Schiene
- Carril superior

MQ13



- Clip blocco binario superiore
- Clip bloquant rail supérieur
- Upper rail hook clip
- Clip sperren Sie die obere Schiene
- Clip bloquean el carril superior

MQ910

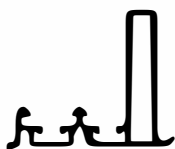

- Binario superiore
- Rail supérieur
- Upper rail
- Obere Schiene
- Carril superior

MQ16



- Clip aggancio binario superiore
- Clip rail supérieur
- Upper rail clip
- Clip obere Schiene
- Clip de superior del carril

MQ911

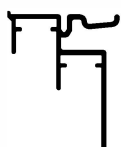

- Binario inferiore
- Rail inférieur
- Lower rail
- Untere Schiene
- Carril inferior

MQ20

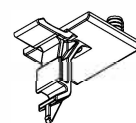

- Clip binario inferiore
- Clip rail inférieur
- Lower rail clip
- Clip untere Schiene
- Clip de inferior del carril

MQ920